

Water Heater Bollard Protection

This bulletin depicts the specifications of a bollard to be used for protecting a water heater installed in a garage from a vehicle impact.

For more information on water heaters, please also see our bulletin, [Water Heater Installation Information](#).

Base Plate 8" X 8" X 1/2"
5/8" Anchor (5/8" X 4" Wedge Anchor or
Concrete Screw Anchor 1600 lb minimum
Allowable Tension at 2-3/4" Embedment)

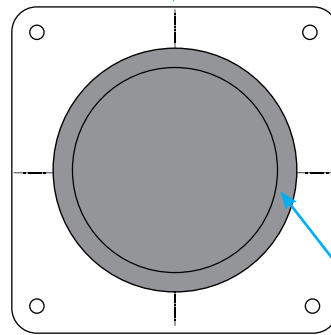

4" Schedule 40 Steel
Pipe 1/4" Minimum
Fillet Weld to Base

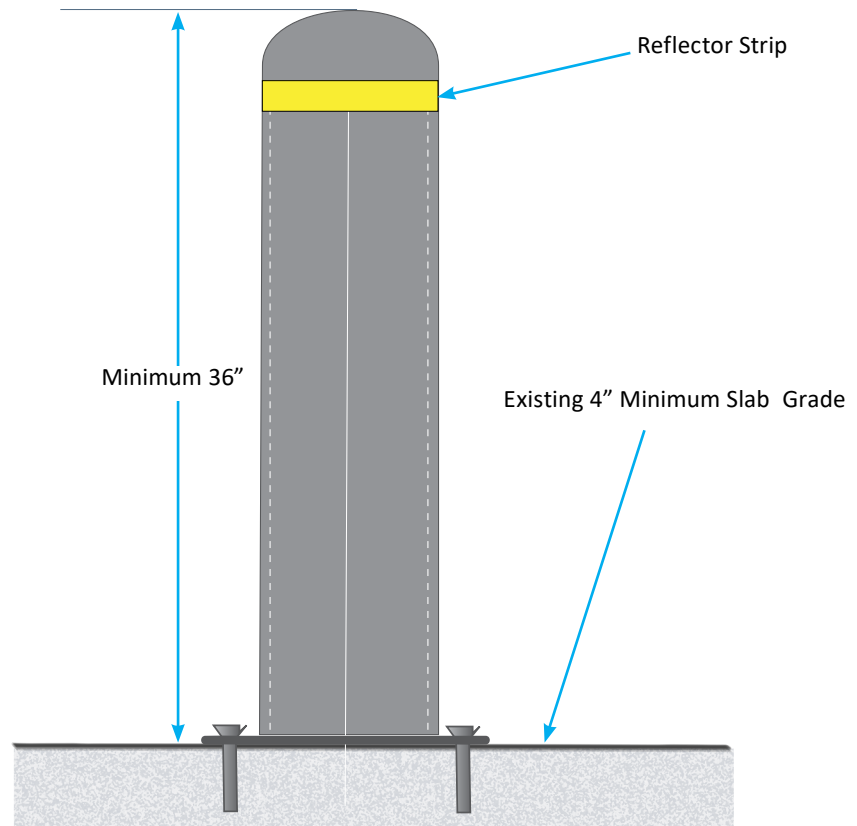

Commercially Available

San José Permit Center
San José City Hall
200 E. Santa Clara St.
San José, CA 95113
408-535-3555
www.sanjoseca.gov/building