

METER BOX WITH BASE; CHRISTY B9, FL9D, B9SL  
BROOKS NO. 36 OR APPROVED EQUAL

BRONZE 1 1/2"-90° ELBOW,  
FLANGE x FEMALE I.P. WITH  
BRASS PLUG.

1 1/2" ANGLE STOP WITH LOCKWINGS;  
MUELLER H-14277  
OR FORD FV43-666WG.

ATTACHED  
SIDEWALK

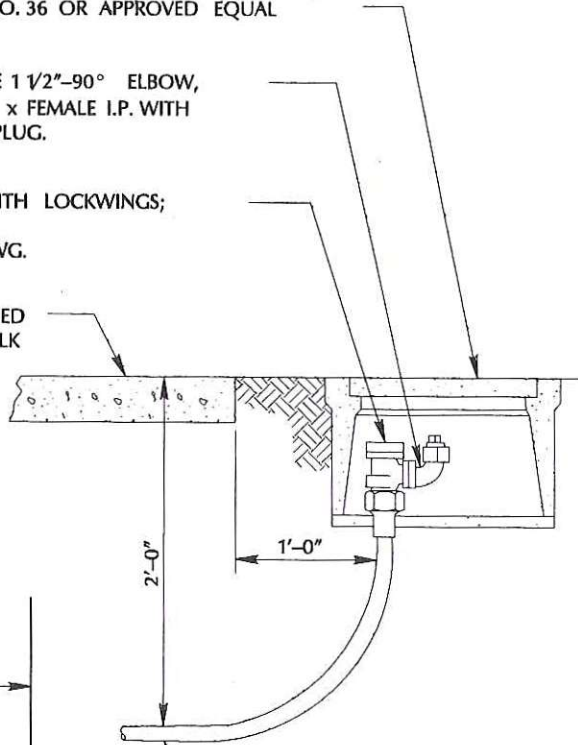

- NOTES: 1. WRAP TIE RODS, STRAIGHT COUPLING  
AND 5' OF COPPER TUBING WITH 10 MIL.  
PVC TAPE, HALF-LAPPED.
2. ENCASE ALL BURIED IRON SURFACES  
WITH POLYETHYLENE WRAP(8 MIL. MIN.)  
AS SPECIFIED IN A.W.W.A. C105.
3. ALTERNATE BLOW OFF ASSEMBLY SHALL  
INCLUDE AN MJ VALVE WITH MEGA LUGS AND  
MJ CAP WITH MAGA LUGS

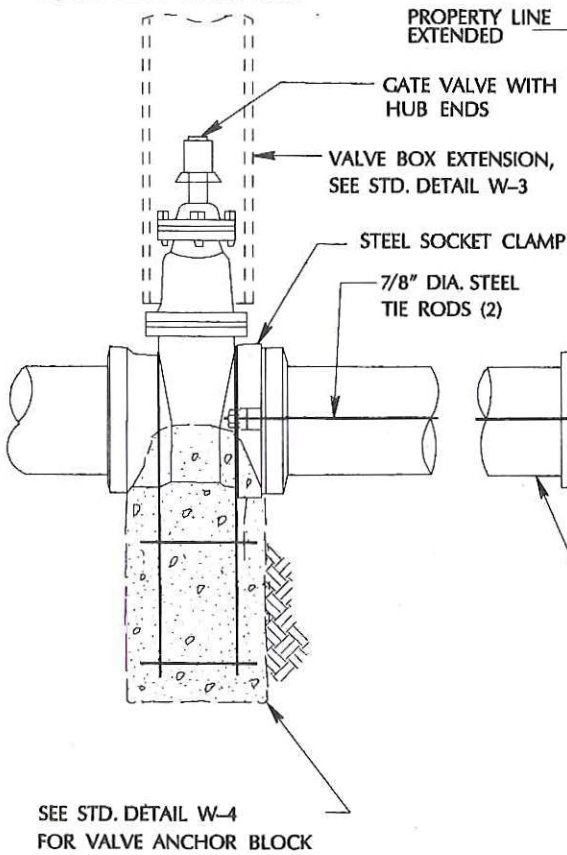

SEE STD. DETAIL W-4  
FOR VALVE ANCHOR BLOCK

1 1/2" TYPE K  
COPPER TUBING

1 1/2" STRAIGHT COUPLING,  
FORD C84-66G  
MUELLER H-15428

2" x 1 1/2" PLASTIC BUSHING

CAST IRON CAP WITH 2"  
TAPPED HOLE AND EARS  
FOR TIE RODS

DIP COUPLING

6'-6" LENGTH DIP

APPROVED BY

*wsh*

DATE

4-2-92

# GATE VALVE BLOW-OFF ASSEMBLY

DEPARTMENT OF PUBLIC WORKS



DRAWING  
NO.

W-10