

# C3PO

City Portfolio-Product-Projects Office

**Mission :**

The mission of the ITD-C3PO division is to provide quality Portfolio, Product and Project management services in a timely and efficient manner, and to work with the cooperation of stakeholders and the community to implement solutions, infrastructure and platforms that are robust and secure for the City of San José. Our interaction with stakeholders and vendors are fair, respectful, professional, and consistent with available human and economic resources.

**Purpose :**

Execute and sustain the enabling technologies that departments depend on to render superior municipal services.



# Technology Investment Management



## Ideas & Plans

- Mayor and Council
- CMO Priorities
- IT Strategic Plan
- IT Governance
- Department Priorities

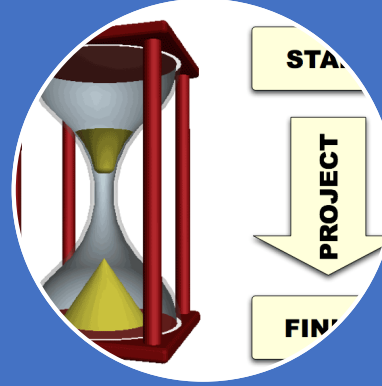

## Project Management

- C3PO Engaged
- Steering Committee
- Documentation
- Charter
- Artifacts/Milestones
- Deployment

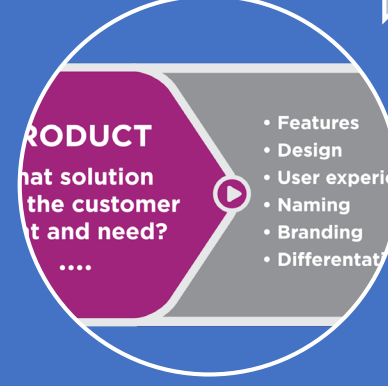

## Product Management

- Executive Committee
- Product Owner & PPM
- Lifecycle Management
- Roadmap
- Vendor/Internal Mgmt.
- Metrics/Value Prop

# Product Portfolio Management

# C3PO in the Mix



Greater  
Than  
\$500,000

OR

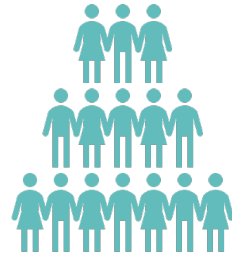

Involves  
More Than  
1 Dept.

OR



Greater  
than 1 Year  
in Execution

OR



High Profile  
or Sensitive  
to the City

+ support and train others on their initiatives throughout the City

Customer Experience Example

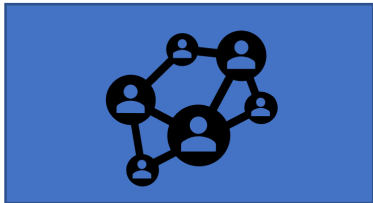

Persons/Processes

Activity

- Illegal Dumping
- Street Light Outage
- Report Pothole
- Aband. Vehicle
- Recycle Plus
- Water Billing
- Resolve A Report
- Language Translate
- Comms

Customer

Voice | App | Chat | V.next – Submit | Inquire | Update/Respond | Close

Dept Employee

Receive | Assign | Dispatch | Work | Close

Physical Env.

Trucks | Materials  
Cloud Host

Technical Env.

OSVC/CRM Messaging | Oracle ICS | Virtual Agent | Chat  
App Order | Unity | Messaging

Support Proc

- Staffing
- Budgeting
- Purchasing
- Spending
- Commitments
- Training
- Roadmap

FTE | LD/OS | Temps | Interns | Assignment | Evaluation  
City Budget Process | Timing | Color of Money  
Policy | Practices | PPB | RFQ/RFB/RFP/RFI  
Fiscal Tracking | Alternatives  
Legal | Standard Practices | IT Terms | Approvals | Routing  
Skills Matrix | Teach | Contract

Change Proc

- Roadmap
- Prioritize
- Chartering
- Execution
- Operationalize
- Vendor Mgmt

Updates | Upgrades | New Features | OKR's | Relations  
Work Plan | Agreement | Alignment  
Project Management | Testing | Acceptance  
Documentation of Work | Transitions | Main/Support

# Portfolio Management

**Portfolio:** a set of processes and technologies needed to accomplish a business goal

**Management:** constant oversight, planning and execution to optimize use and value of technologies to improve people's ability to accomplish the business goals

## Product Management

- Management of Value
  - What we have
  - What we need
  - What we'll need to be



## Project Management

- Incremental Value
  - Discrete Change
  - Limited Time
  - Measured Result

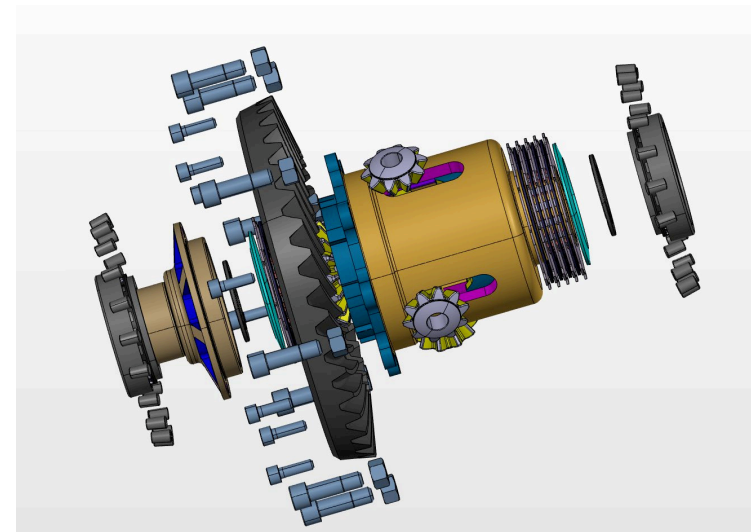



City Stakeholders

# The PPM: The People, Process and Technology Conduit



Infrastructure



Cyber Security



Sponsor



Steering Committee



Product Project Manager

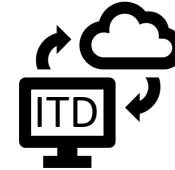

Data



Product/Service Owner



Technical Architect



Digital Privacy



Users

...And Many More



UI/UX Design

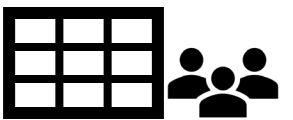

Business Solutions

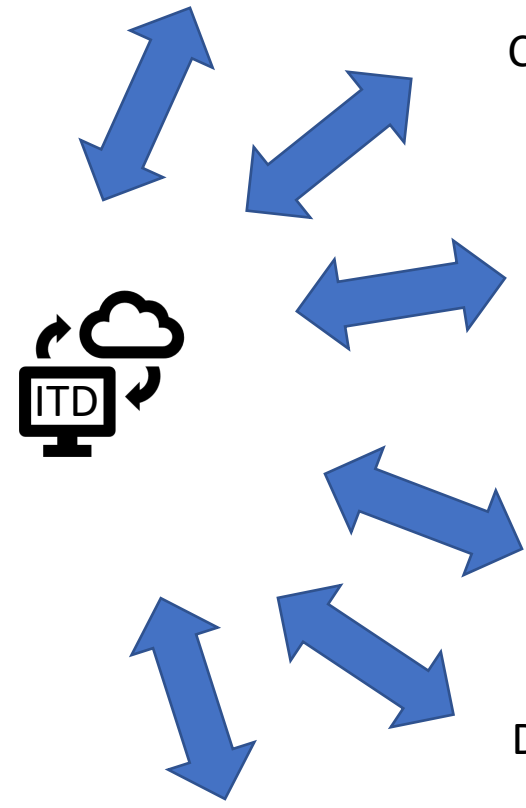
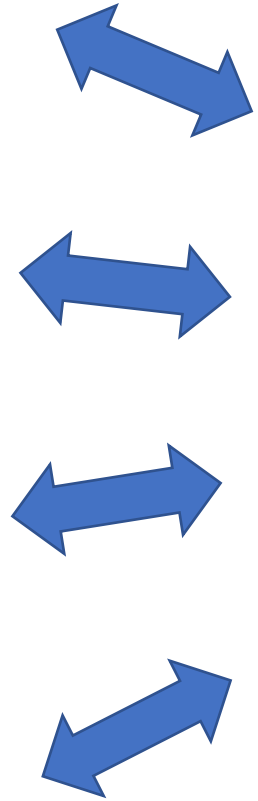



# Product Project Managers



Ashish



Swati



Sudheer



Erica



German

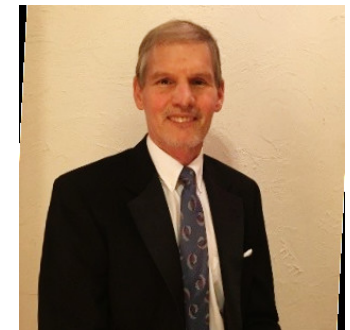

Stafford

Help Is On The Way!