

SIGNING AND STRIPING NOTES:

1. ALL STRIPING, PAVEMENT MARKERS AND MARKINGS INSTALLATION TO BE PERFORMED BY THE CONTRACTOR.
2. ALL STRIPING, PAVEMENT MARKERS AND MARKINGS REMOVAL TO BE PERFORMED BY THE CONTRACTOR PER THE CITY OF SAN JOSE STANDARD SPECIFICATIONS. ALL STRIPING, PAVEMENT MARKERS AND MARKINGS THAT ARE IN CONFLICT WITH THE NEW INSTALLATION MUST BE REMOVED BY THE CONTRACTOR.
3. ALL STRIPING, PAVEMENT MARKERS AND MARKINGS LAYOUT (CAT-TRACKING) SHALL BE DONE BY THE CONTRACTOR PRIOR TO PLACEMENT.
4. PROJECT INSPECTOR SHALL NOTIFY THE DEPARTMENT OF TRANSPORTATION (GEOMETRIC DESIGN) AT (408)535-3850 A MINIMUM OF TWO WEEKS PRIOR TO THE NEED TO ARRANGE FOR THE STRIPING INSTALLATION.
5. UNLESS INDICATED OTHERWISE, ALL STRIPING, PAVEMENT MARKERS AND MARKINGS, AND SIGNS INSTALLATION ARE PER THE LATEST CALIFORNIA MUTCD, CALTRANS STANDARD PLANS AND SPECIFICATIONS.
6. THE WIDTH OF THE CROSSWALK SHALL BE MEASURED FROM CENTER OF STRIPING ON ONE SIDE TO CENTER OF STRIPING ON THE OTHER SIDE.
7. UNLESS INDICATED OTHERWISE, NUMBER ONE LANE DIMENSIONS SHALL BE MEASURED FROM MEDIAN FACE OF CURB TO CENTER OF STRIPING WHERE MEDIAN IS PRESENT; OTHERWISE LANE DIMENSIONS SHALL BE MEASURED FROM CENTER OF STRIPING TO CENTER OF STRIPING.
8. CENTER LANE DIMENSIONS SHALL BE MEASURED FROM CENTER OF STRIPING TO CENTER OF STRIPING.
9. WHERE BIKE LANE IS NEXT TO FACE OF CURB, BIKE LANE DIMENSIONS SHALL BE MEASURED FROM CENTER OF STRIPING TO FACE OF CURB.
10. WHERE BIKE LANE IS NOT PRESENT BETWEEN FACE OF CURB AND CURB LANE, CURB LANE DIMENSIONS SHALL BE MEASURED FROM CENTER OF STRIPING TO FACE OF CURB.

LEGEND:

- INSTALLATION OF PROPOSED SIGN ON EXISTING LIGHTING, SIGNAL OR SIGN POLE BY STRAP AND SADDLE BRACKET METHOD
- INSTALLATION OF PROPOSED SIGN WITH NEW 2" STEEL SIGN POLE
- PROPOSED / EXISTING SIGN ON EXISTING POLE
- INSTALLATION OF PROPOSED SIGN ON EXISTING POLE
- REMOVE EXISTING SIGN ON EXISTING POLE
- REMOVE EXISTING SIGN AND POLE
- EXISTING SIGN TO REMAIN
- INSTALL 4'X6' TYPE D BIKE LOOP
- INSTALL 6'X6' TYPE D LOOP DETECTOR
- INSTALL 6'X20' TYPE C LOOP DETECTOR
- INSTALL 6'X6' TYPE Q LOOP DETECTOR
- CITY STRIPING AND MARKING DETAILS (SEE LOWER LEFT-HAND CORNER FOR EQUIVALENT STANDARD CALTRANS STRIPING AND MARKING DETAILS)
- DIRECTION OF TRAVEL
- BIKE BOULEVARD MARKING

ABBREVIATIONS:

- BL BIKE LANE ARROW AND BIKE WITH PERSON SYMBOL
- SR SHARED LANE MARKING (SHARROW)
- LTA TYPE IV ARROW (LEFT)
- RTA TYPE IV ARROW (RIGHT)
- L/RA TYPE VIII ARROW (LEFT AND RIGHT)
- L/TA TYPE VII ARROW (LEFT AND THROUGH)
- R/TA TYPE VII ARROW (RIGHT AND THROUGH)
- LMA TYPE VI ARROW (LEFT MERGE LANE)
- RR RAILROAD CROSSING SYMBOL
- NTS NOT TO SCALE
- O.C. ON CENTER
- TYP TYPICAL

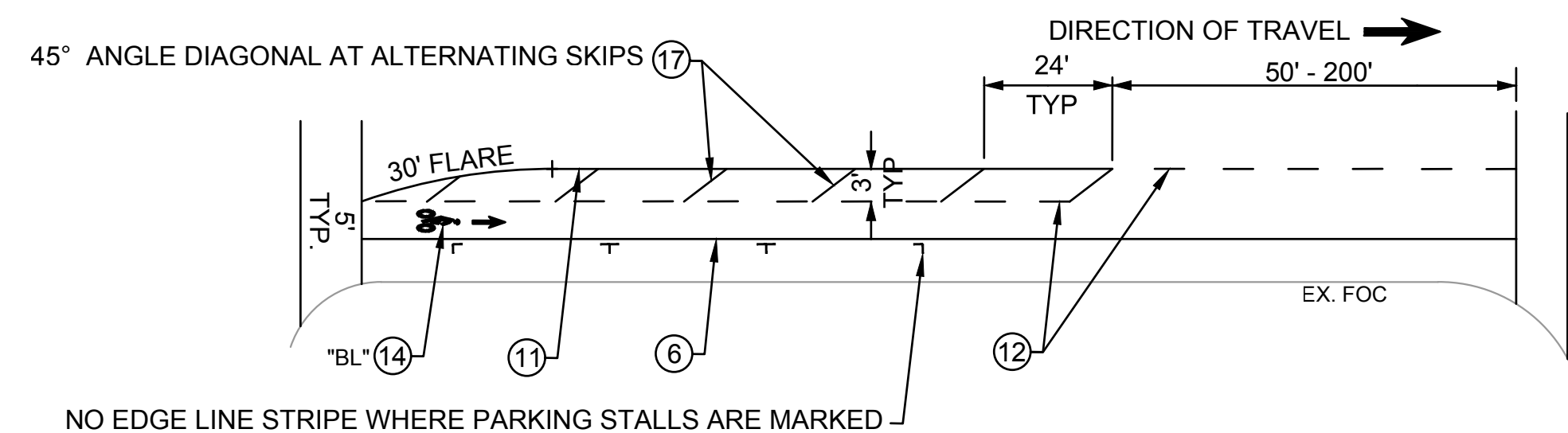

DETAIL A
BUFFERED BIKE LANE AT UNSIGNALIZED INTERSECTIONS W/ PARKING
NTS

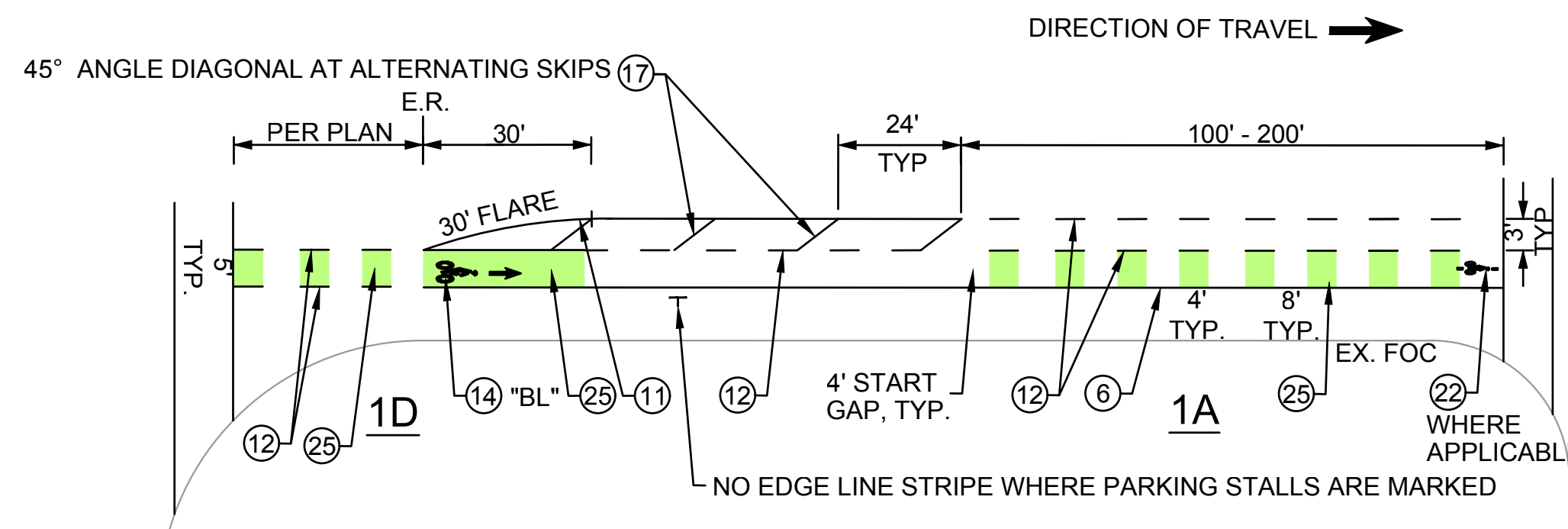

DETAIL B
BUFFERED BIKE LANE AT SIGNALIZED INTERSECTIONS W/ PARKING
NTS

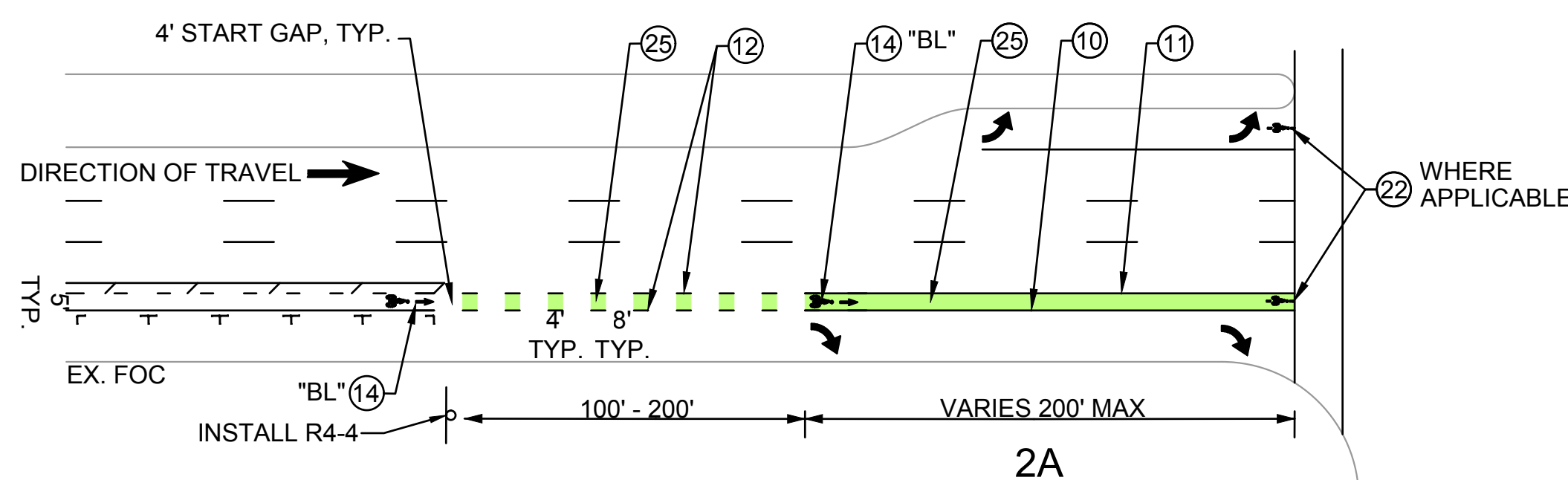

DETAIL C
INTERSECTIONS W/ RIGHT TURN BAY
NTS

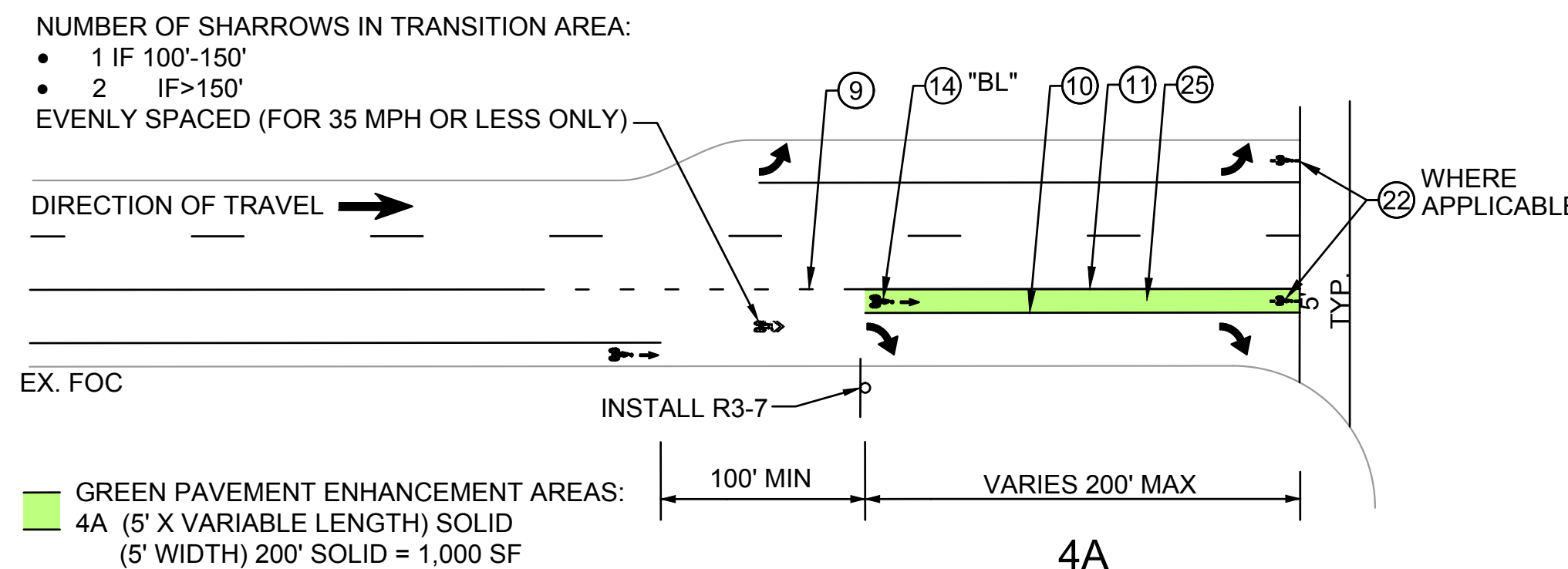

DETAIL D
INTERSECTIONS W/ DROP LANE/RIGHT TURN BAY
NTS

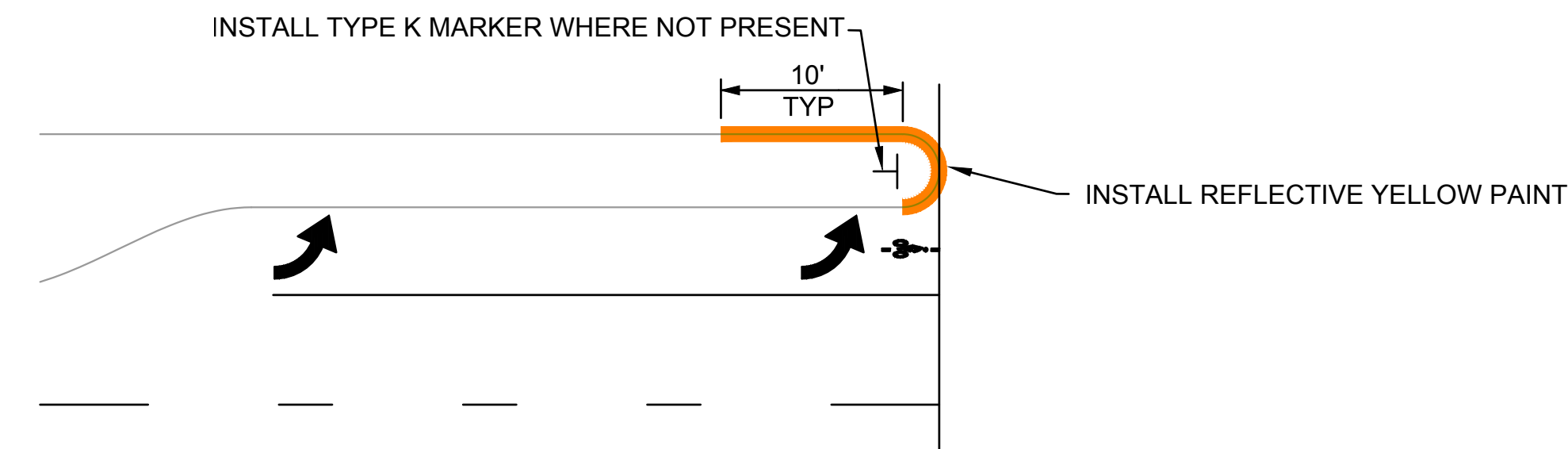

DETAIL E
MEDIAN NOSE TREATMENT AT INTERSECTION
NTS

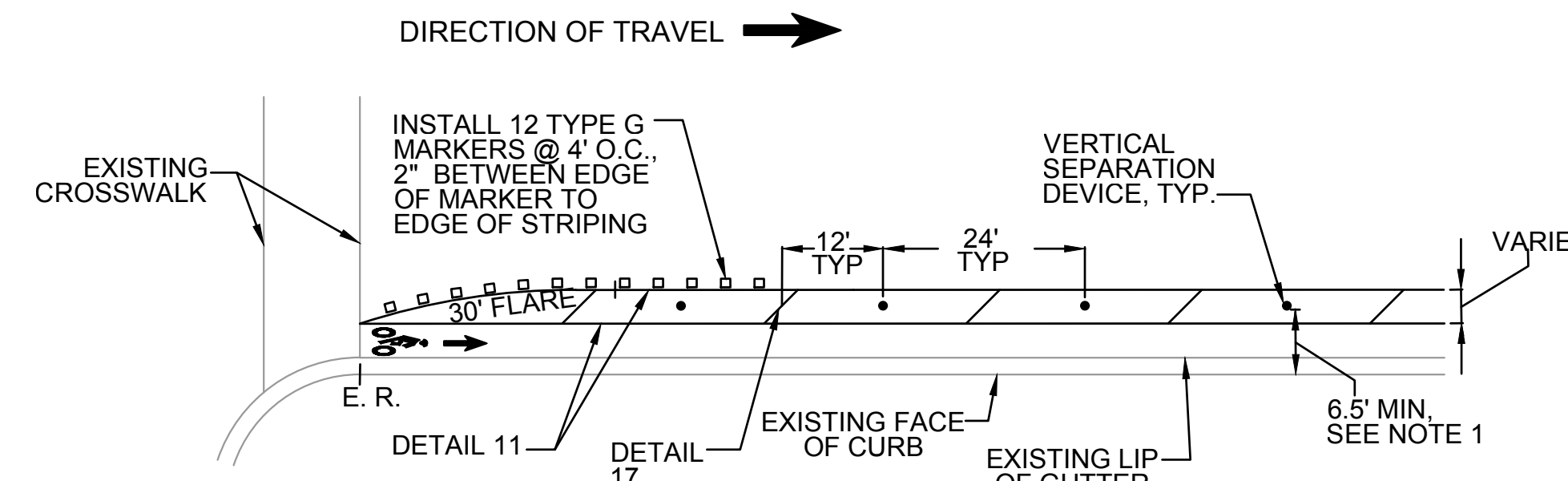

DETAIL F
SEPARATED BICYCLE LANE AT INTERSECTION
NTS

NOTES (FOR DETAIL F AND G):

1. INSTALL VERTICAL SEPARATION DEVICE TYPICALLY IN THE CENTER OF BIKE BUFFER, PROVIDE 6.5' MINIMUM BETWEEN CENTER OF VERTICAL SEPARATION DEVICE AND FACE OF CURB.
2. DROP VERTICAL SEPARATION DEVICES THROUGH 40' MINIMUM APPROACH AND 20' MINIMUM DEPARTURE OF DRIVEWAYS.
3. DROP VERTICAL SEPARATION DEVICES IN FRONT OF BUS STOPS AND WITHIN 50' DEPARTING ZONE BEYOND BUS STOPS.
4. WHERE MEDIAN IS PRESENT, PROVIDE 20' MIN BETWEEN MEDIAN FACE OF CURB AND THE EDGE OF VERTICAL SEPARATION DEVICES.

1. STATE DETAIL 9 (MOD. TYPE C MARKER)	8. STATE DETAIL 32	15. CHATTER BARS	22. BIKE LOOP DETECTOR SYMBOL
2. STATE DETAIL 12 (MOD. TYPE C MARKER)	9. STATE DETAIL 37B	16. RESERVED FOR FUTURE USE	23. RESERVED FOR FUTURE USE
3. STATE DETAIL 22	10. STATE DETAIL 38	17. SOLID 12" WHITE	24. YIELD LINE
4. RESERVED FOR FUTURE USE	11. STATE DETAIL 39	18. SOLID 12" YELLOW	25. GREEN PAVEMENT ENHANCEMENT
5. STATE DETAIL 25	12. STATE DETAIL 39A	19. SOLID 24" WHITE	26. RESERVED FOR FUTURE USE
6. STATE DETAIL 27B	13. RESERVED FOR FUTURE USE	20. STATE DETAIL 26 (MOD. 24" SPACING)	27. SOLID 24" YELLOW
7. STATE DETAIL 29	14. ARROW/MESSAGES	21. STATE DETAIL 40	28. STATE DETAIL 41

REVISIONS	DATE

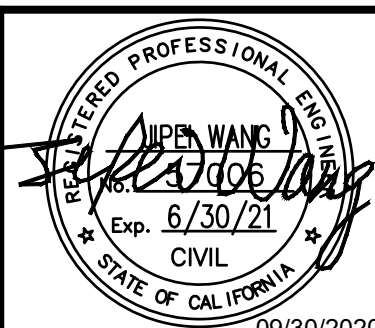

NOTES, LEGEND AND BIKE LANE MARKING DETAILS
SAN ANTONIO STREET
BETWEEN S 17TH STREET AND S JACKSON AVENUE
SIGNING AND STRIPING PLAN



DEPARTMENT OF TRANSPORTATION SAN JOSE, CALIFORNIA	
DRAWN BY: _____	JOHN RISTOW DIRECTOR
CHECKED BY: _____	
PROJ MGR: _____	
DATE: _____	
SCALE: _____	
SHEET NO. 1 OF 11	FILE NO. _____

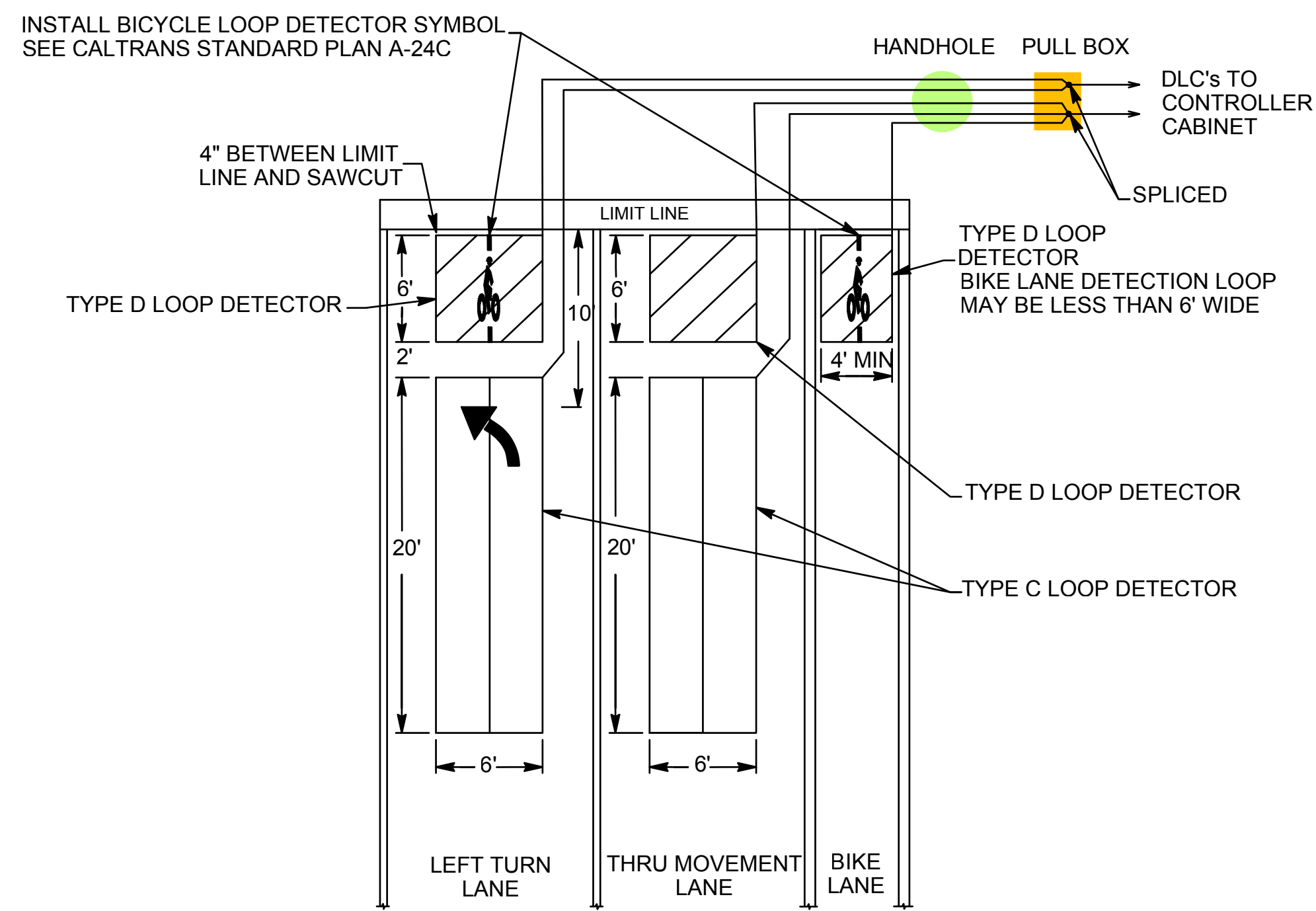

1. IF DETECTOR LOOP CABLES ARE IN ACCEPTABLE CONDITION, THEY MAY BE REUSED. IF NOT, THEY SHALL BE REPLACED.
2. REFER TO CALTRANS STANDARD PLAN ES-5B FOR DETECTION LOOP SAWCUT AND WINDING DETAILS.
3. LOOPS SHALL BE CENTERED IN LANES EXCEPT FOR CURB LANES GREATER THAN 12 FEET WHERE THEY SHALL BE INSTALLED 3 FEET FROM THE LANE, UNLESS SPECIFIED OTHERWISE ON THE PLANS.
4. SEE CSJ STANDARD DETAILS E-71 AND E-72, AND CSJ STANDARD SPECIFICATION 86-5 FOR OTHER REQUIREMENTS.
5. ALL WORK SHALL BE COORDINATED WITH CSJ DEPARTMENT OF TRANSPORTATION (DOT) ELECTRICAL MAINTENANCE SECTION.

DETAIL G
BICYCLE DETECTOR SYMBOL LAYOUT - DETAIL
NTS

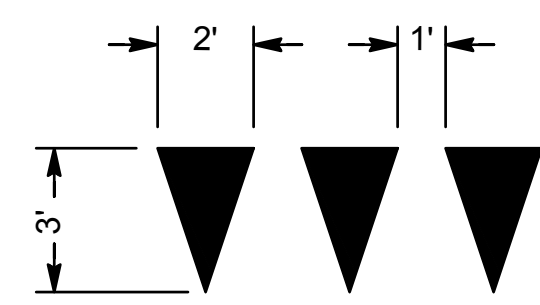

DETAIL H
YIELD LINE
NTS

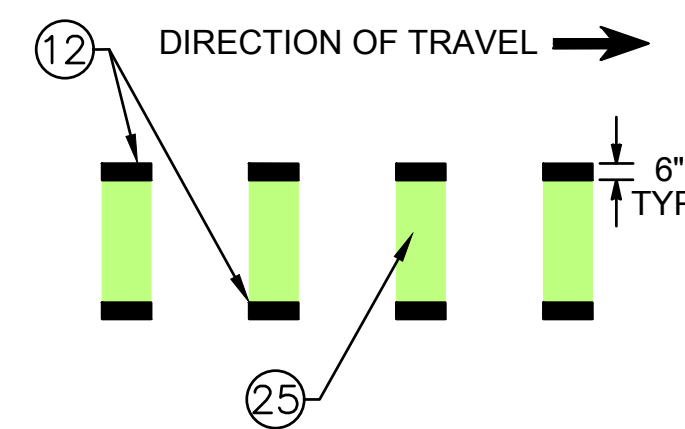

DETAIL I
GREEN BIKE LANE PAVEMENT MARKING (TYP.)
NTS

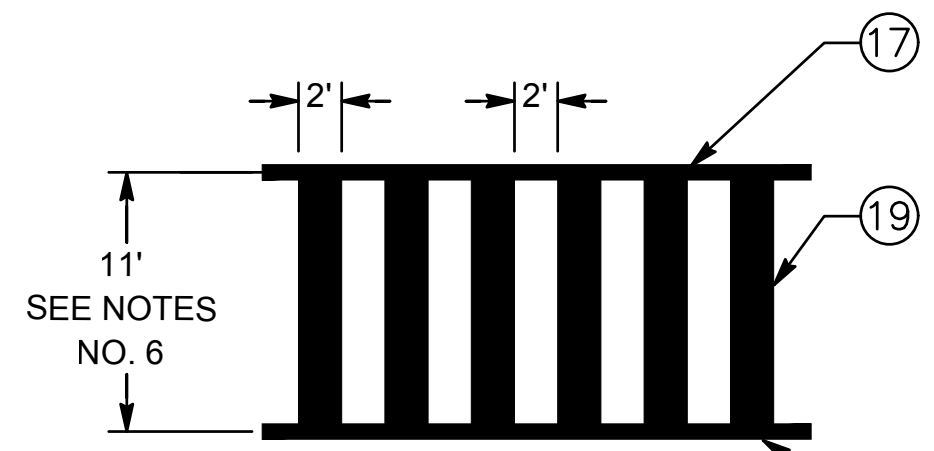

DETAIL J
LADDER CROSSWALK STRIPING
NTS

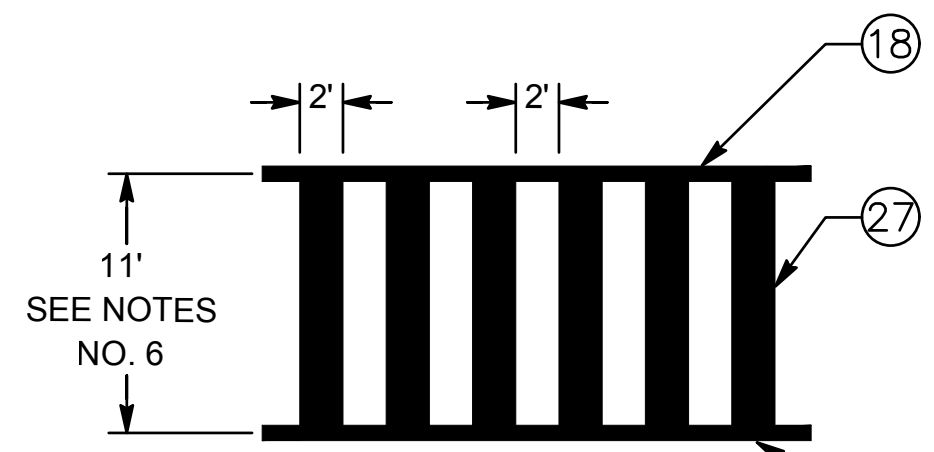

DETAIL K
LADDER CROSSWALK STRIPING (SCHOOL)
NTS

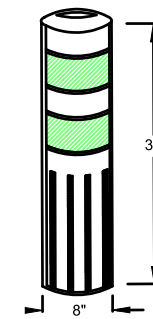

DETAIL L
VERTICAL SEPERATION DEVICE DETAIL WHITE (TYP.)
OPTIONAL: YELLOW (Y)
NTS

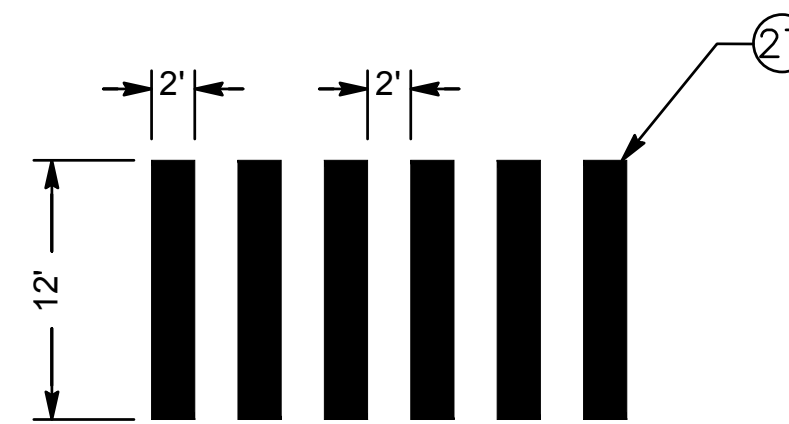

DETAIL M
CONTINENTAL CROSSWALK STRIPING (SCHOOL)
NTS

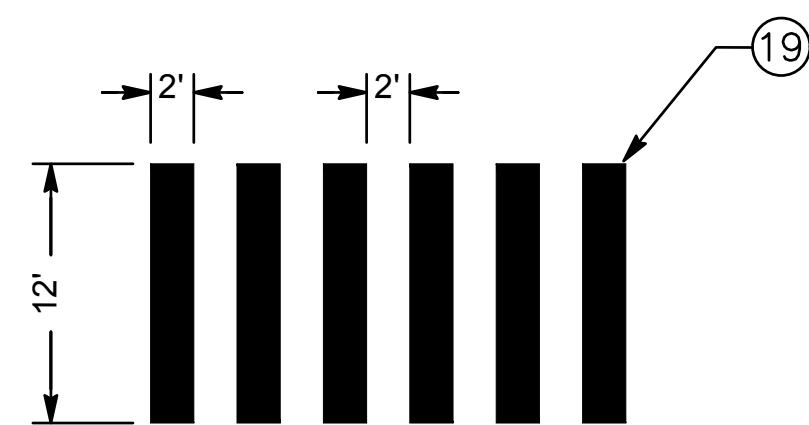

DETAIL N
CONTINENTAL CROSSWALK STRIPING
NTS

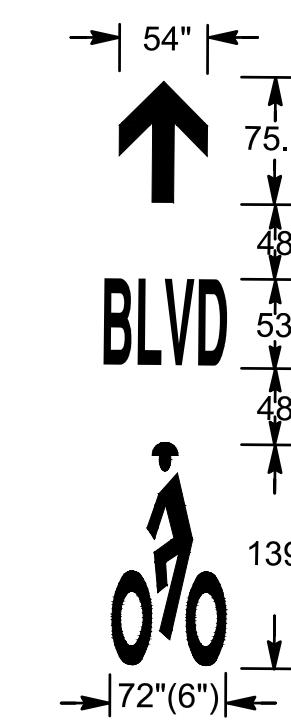

DETAIL O
BIKE BOULEVARD MARKING
NTS

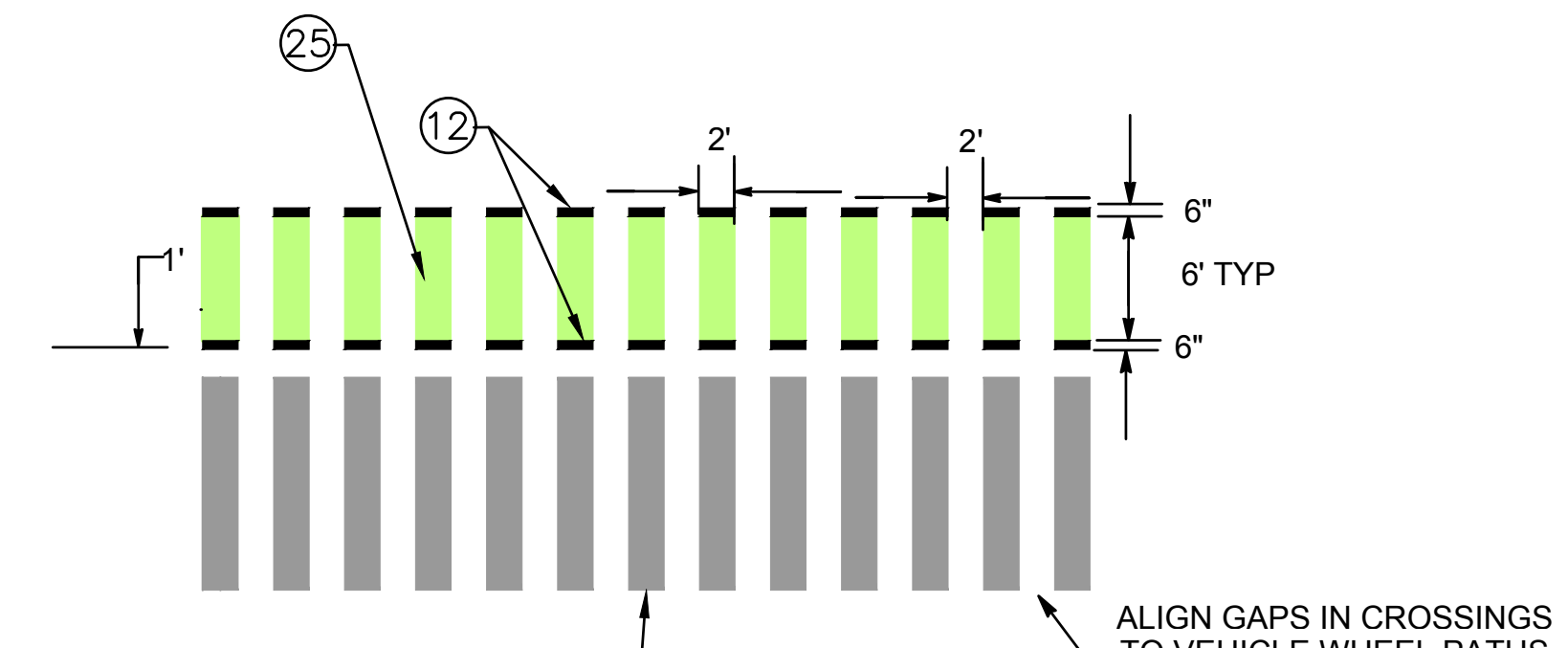

DETAIL P
CROSS BIKE
NTS

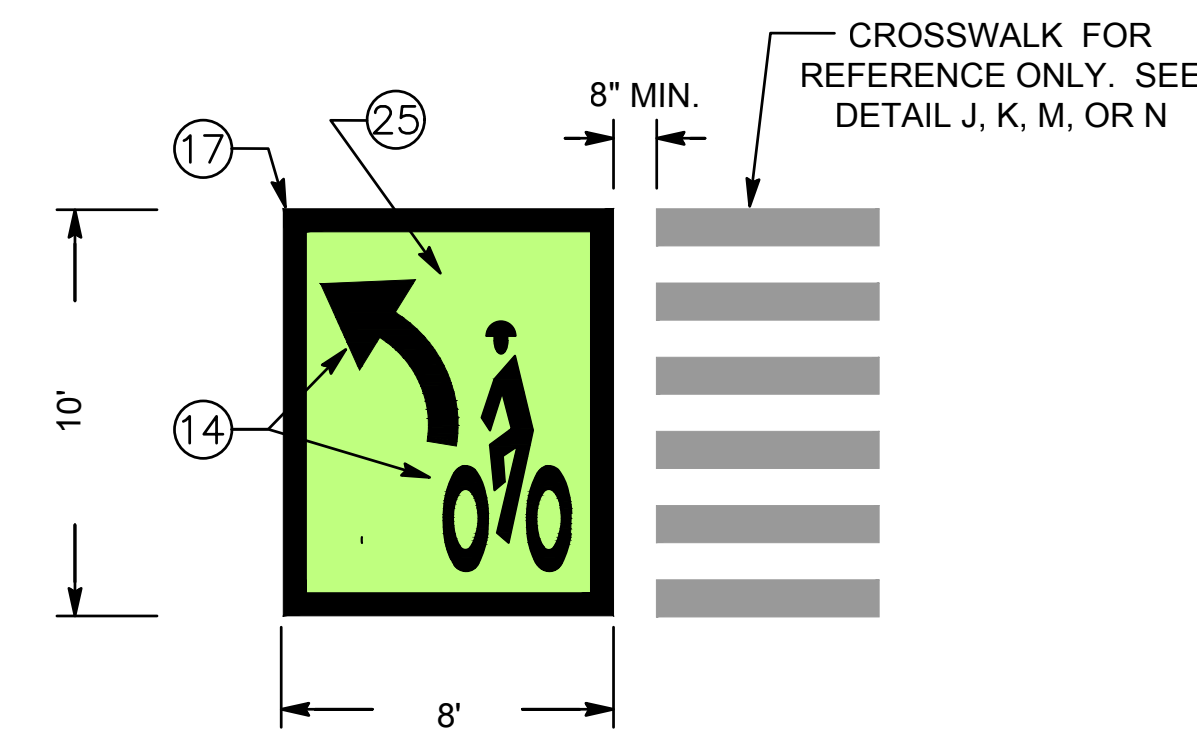

DETAIL Q
TWO-STAGE BICYCLE TURN BOX
NTS

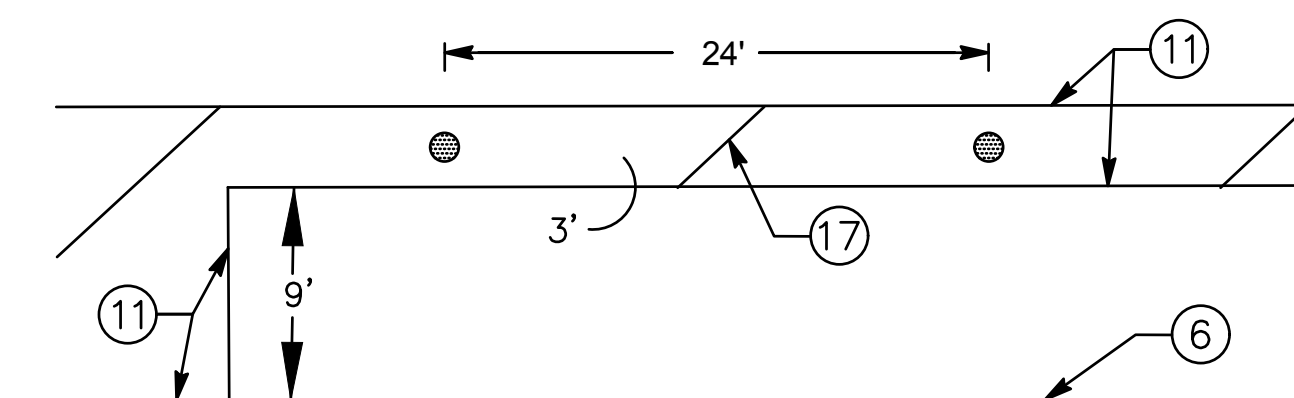

DETAIL R
TYPICAL PARKING STALL DIMENSION
NTS

1. STATE DETAIL 9 (MOD. TYPE C MARKER)	8. STATE DETAIL 32	15. CHATTER BARS	22. BIKE LOOP DETECTOR SYMBOL
2. STATE DETAIL 12 (MOD. TYPE C MARKER)	9. STATE DETAIL 37B	16. RESERVED FOR FUTURE USE	23. RESERVED FOR FUTURE USE
3. STATE DETAIL 22	10. STATE DETAIL 38	17. SOLID 12" WHITE	24. YIELD LINE
4. RESERVED FOR FUTURE USE	11. STATE DETAIL 39	18. SOLID 12" YELLOW	25. GREEN PAVEMENT ENHANCEMENT
5. STATE DETAIL 25	12. STATE DETAIL 39A	19. SOLID 24" WHITE	26. RESERVED FOR FUTURE USE
6. STATE DETAIL 27B	13. RESERVED FOR FUTURE USE	20. STATE DETAIL 26 (MOD. 24" SPACING)	27. SOLID 24" YELLOW
7. STATE DETAIL 29	14. ARROW/MESSAGES	21. STATE DETAIL 40	28. STATE DETAIL 41

REVISIONS	DATE

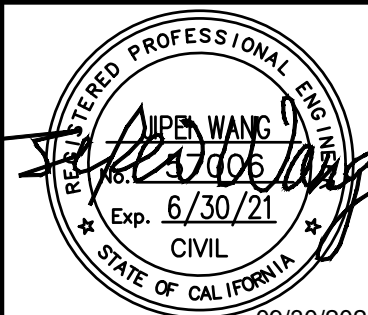

NOTES, LEGEND AND BIKE LANE MARKING DETAILS
SAN ANTONIO STREET
BETWEEN S 17TH STREET AND S JACKSON AVENUE
SIGNING AND STRIPING PLAN



DEPARTMENT OF TRANSPORTATION SAN JOSE, CALIFORNIA	
DRAWN BY: _____	JOHN RISTOW DIRECTOR
CHECKED BY: _____	
PROJ MGR: _____	
DATE: _____	
SCALE: _____	
SHEET NO. _____ OF _____	FILE NO. _____

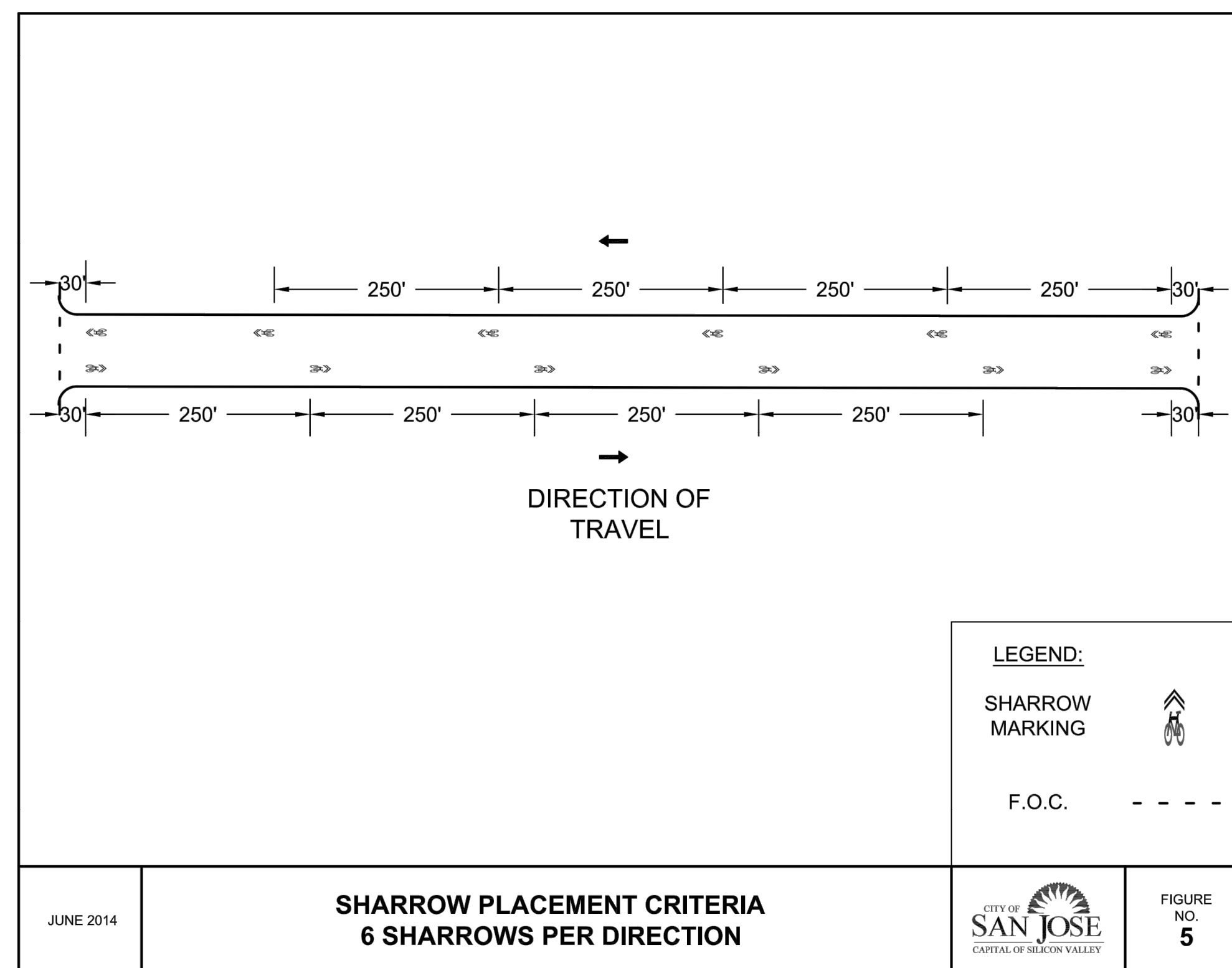
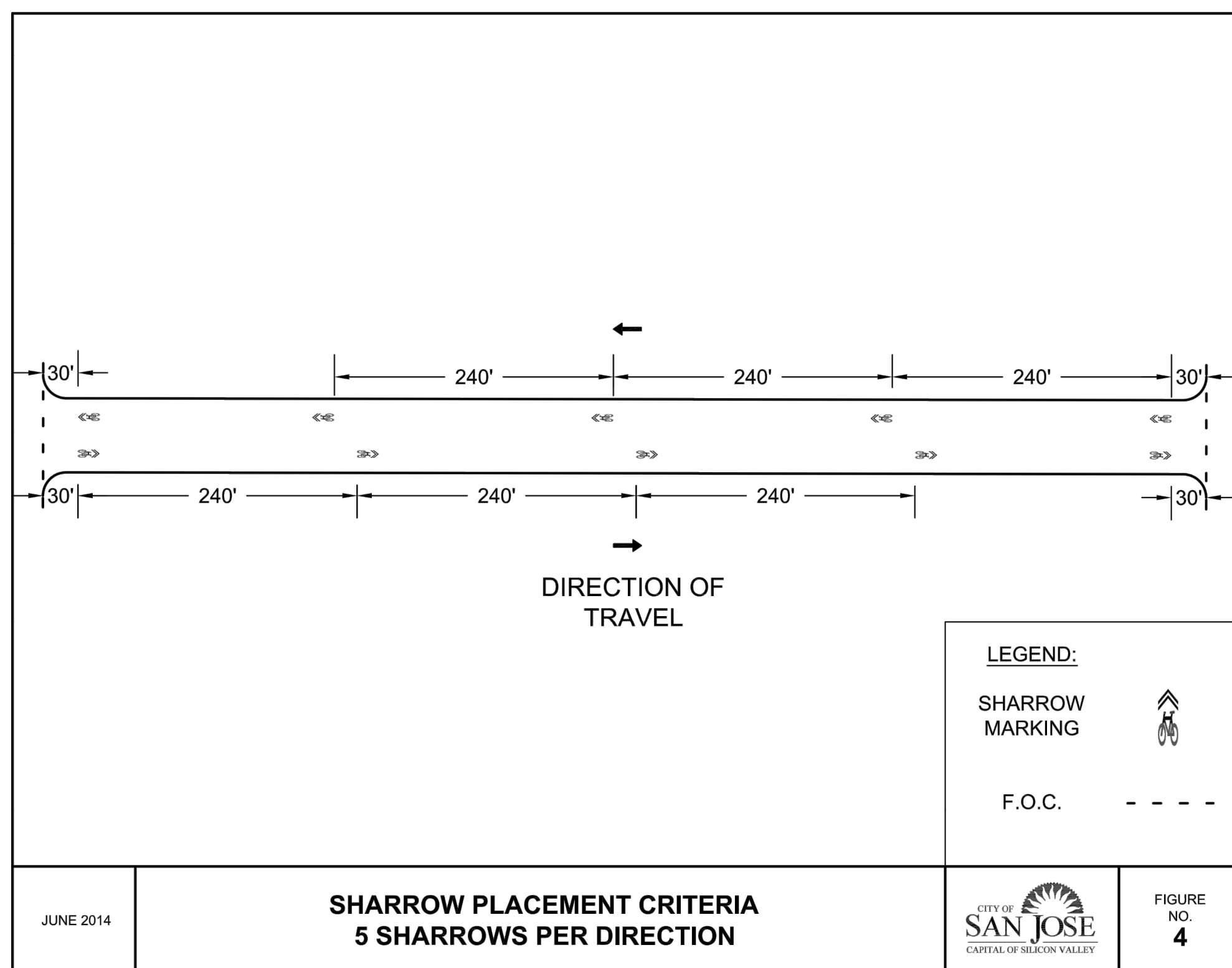
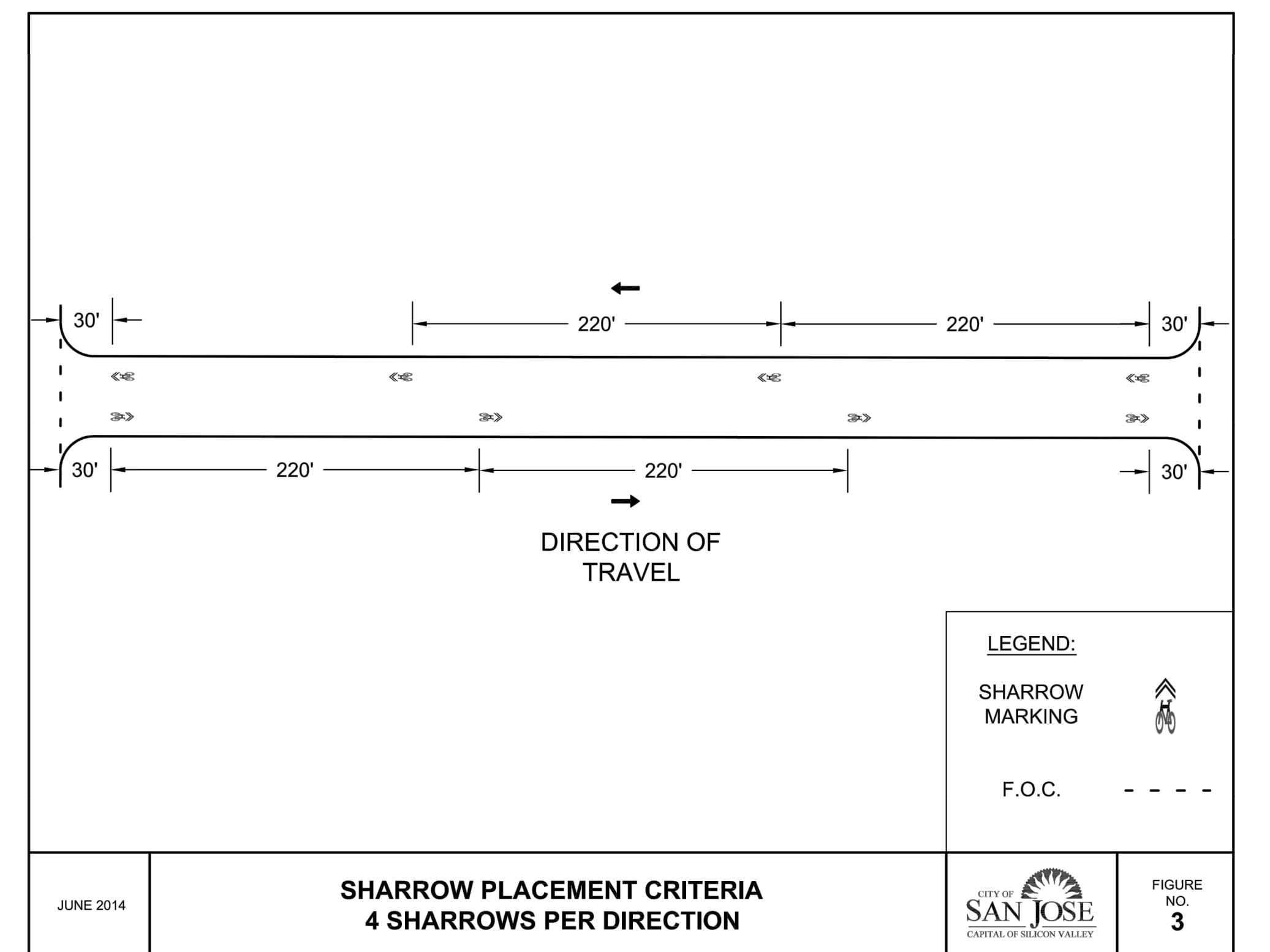
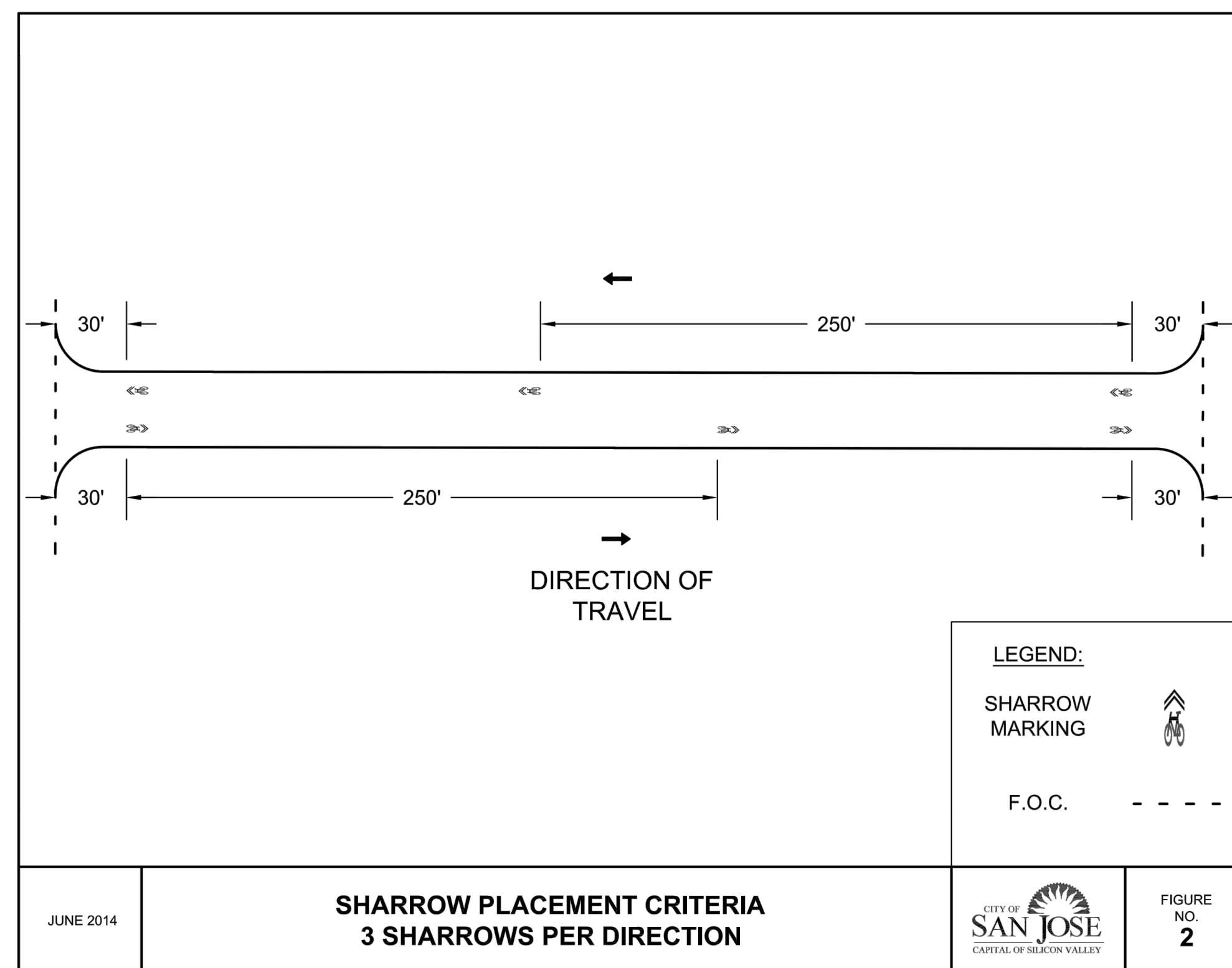
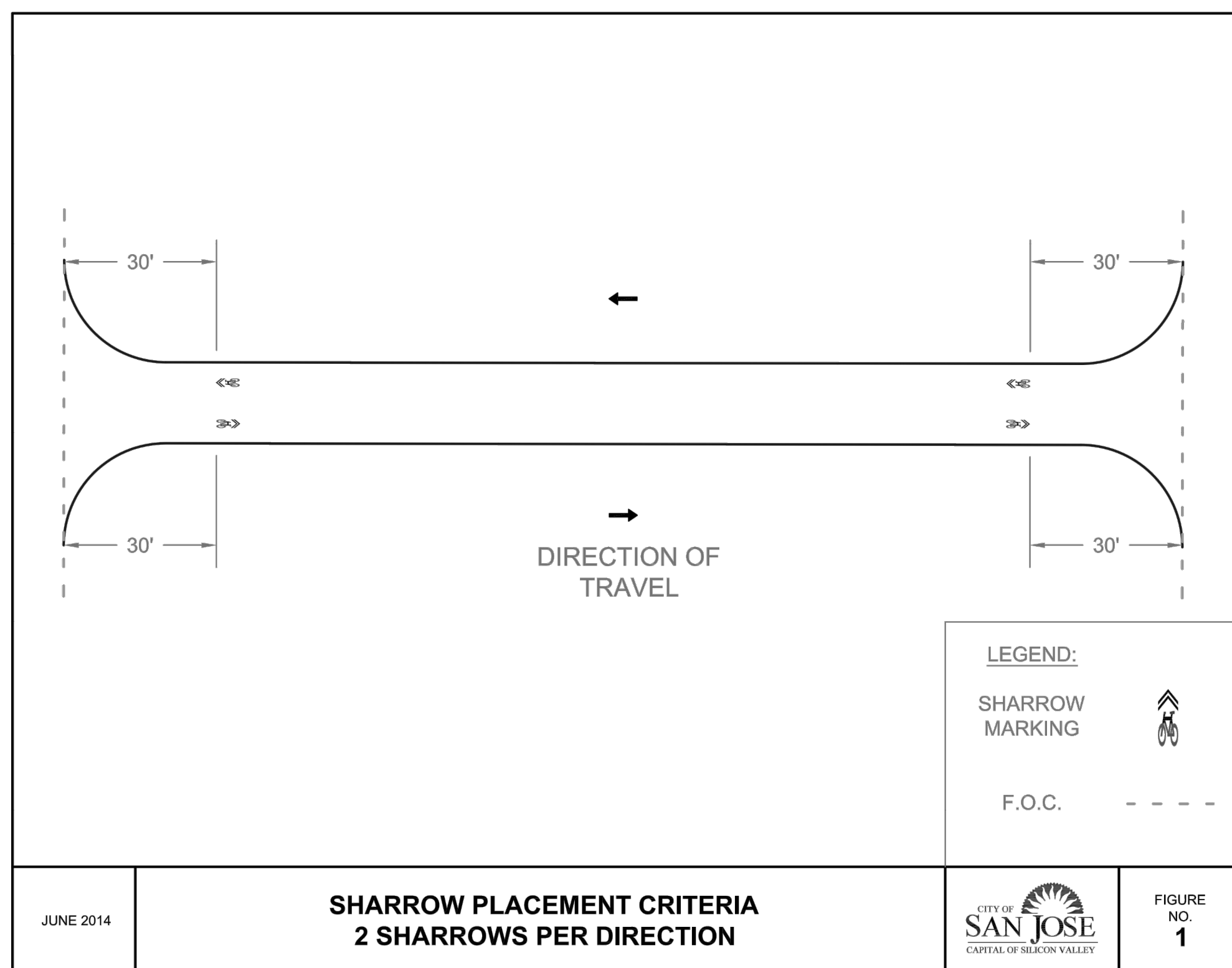

DETAIL S
SHARROW PLACEMENT DETAIL
NTS

1. STATE DETAIL 9 (MOD. TYPE C MARKER)	8. STATE DETAIL 32	15. CHATTER BARS	22. BIKE LOOP DETECTOR SYMBOL
2. STATE DETAIL 12 (MOD. TYPE C MARKER)	9. STATE DETAIL 37B	16. RESERVED FOR FUTURE USE	23. RESERVED FOR FUTURE USE
3. STATE DETAIL 22	10. STATE DETAIL 38	17. SOLID 12" WHITE	24. YIELD LINE
4. RESERVED FOR FUTURE USE	11. STATE DETAIL 39	18. SOLID 12" YELLOW	25. GREEN PAVEMENT ENHANCEMENT
5. STATE DETAIL 25	12. STATE DETAIL 39A	19. SOLID 24" WHITE	26. RESERVED FOR FUTURE USE
6. STATE DETAIL 27B	13. RESERVED FOR FUTURE USE	20. STATE DETAIL 26 (MOD. 24" SPACING)	27. SOLID 24" YELLOW
7. STATE DETAIL 29	14. ARROW/MESSAGES	21. STATE DETAIL 40	28. STATE DETAIL 41

NO.	REVISIONS	DATE
6		
5		
4		
3		
2		
1		

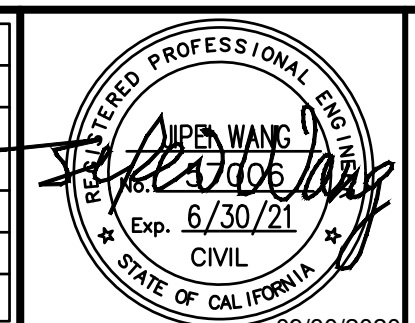

NOTES, LEGEND AND BIKE LANE MARKING DETAILS
SAN ANTONIO STREET
BETWEEN S 17TH STREET AND S JACKSON AVENUE
SIGNING AND STRIPING PLAN



DEPARTMENT OF TRANSPORTATION SAN JOSE, CALIFORNIA	
DRAWN BY: _____	JOHN RISTOW DIRECTOR
CHECKED BY: _____	
PROJ MGR: _____	
DATE: _____	
SCALE: _____	
SHEET NO. 3 OF 11	FILE NO. _____

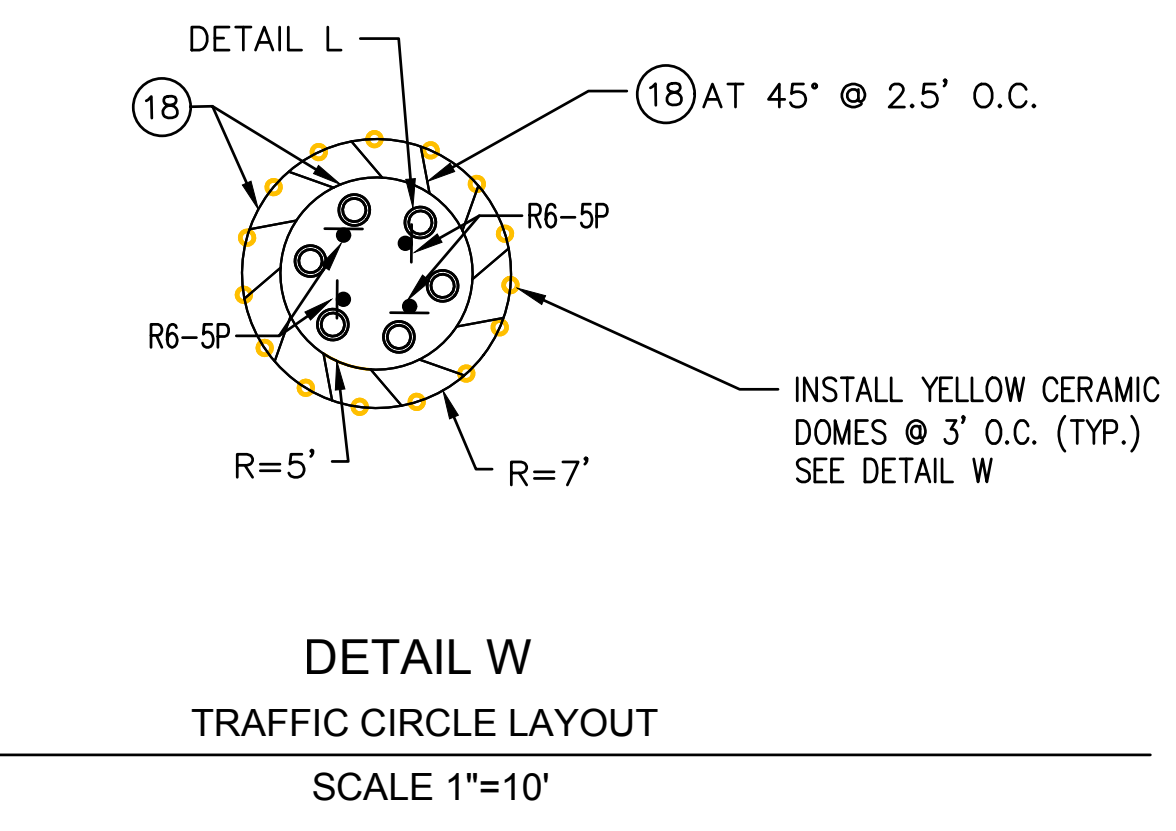
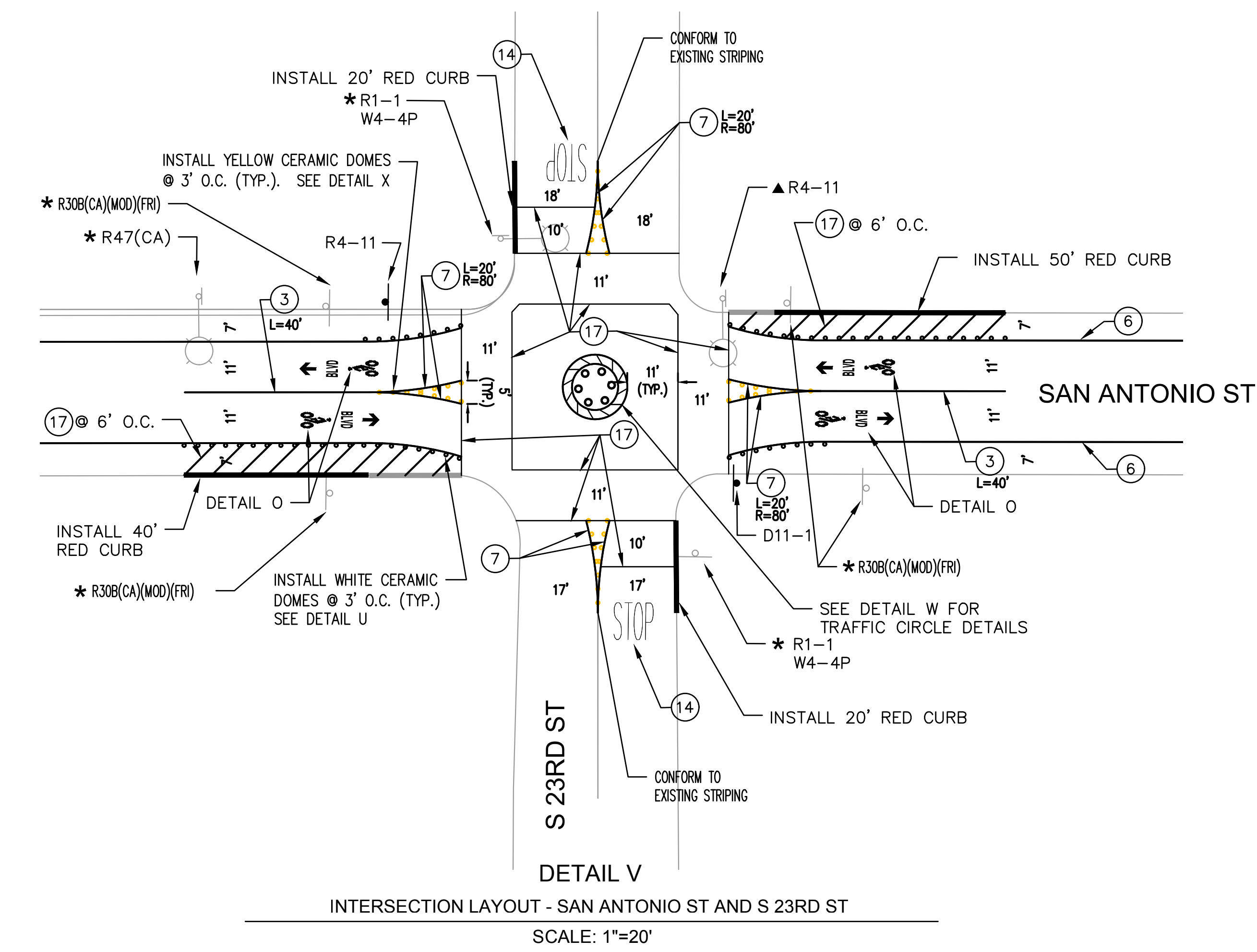
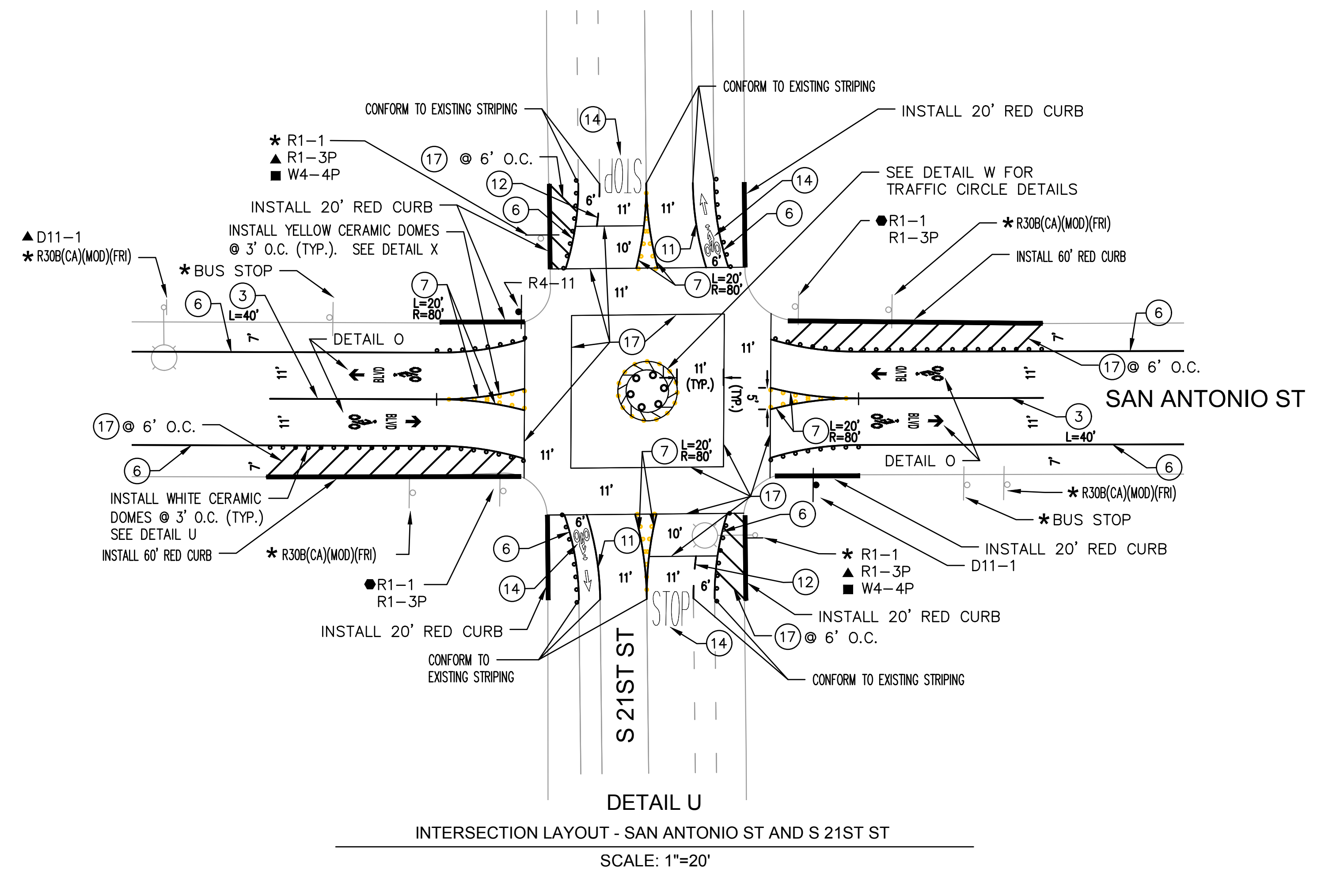
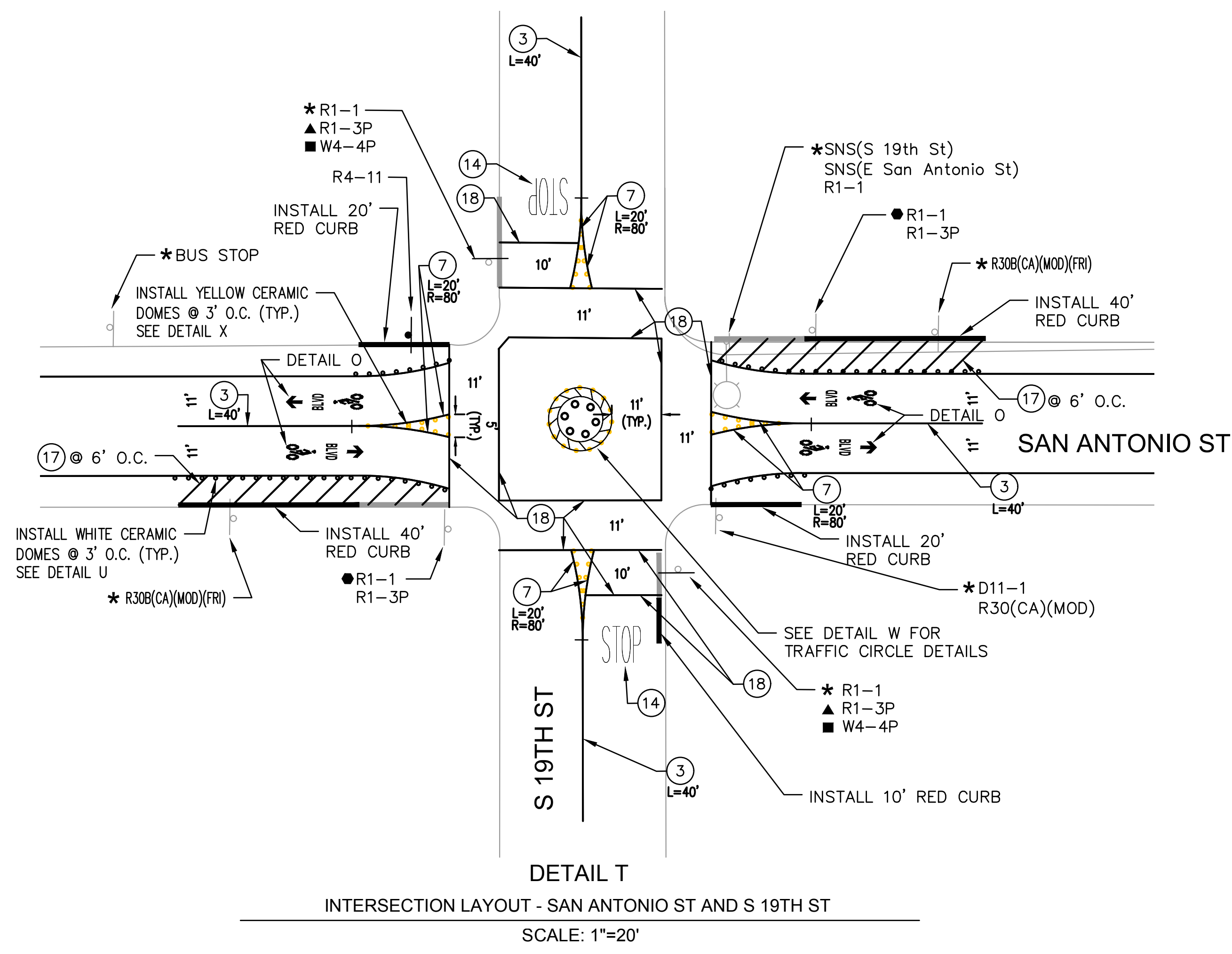

DETAIL X
CERAMIC DOME TRAFFIC MARKERS
(79) YELLOW (61) WHITE
NTS

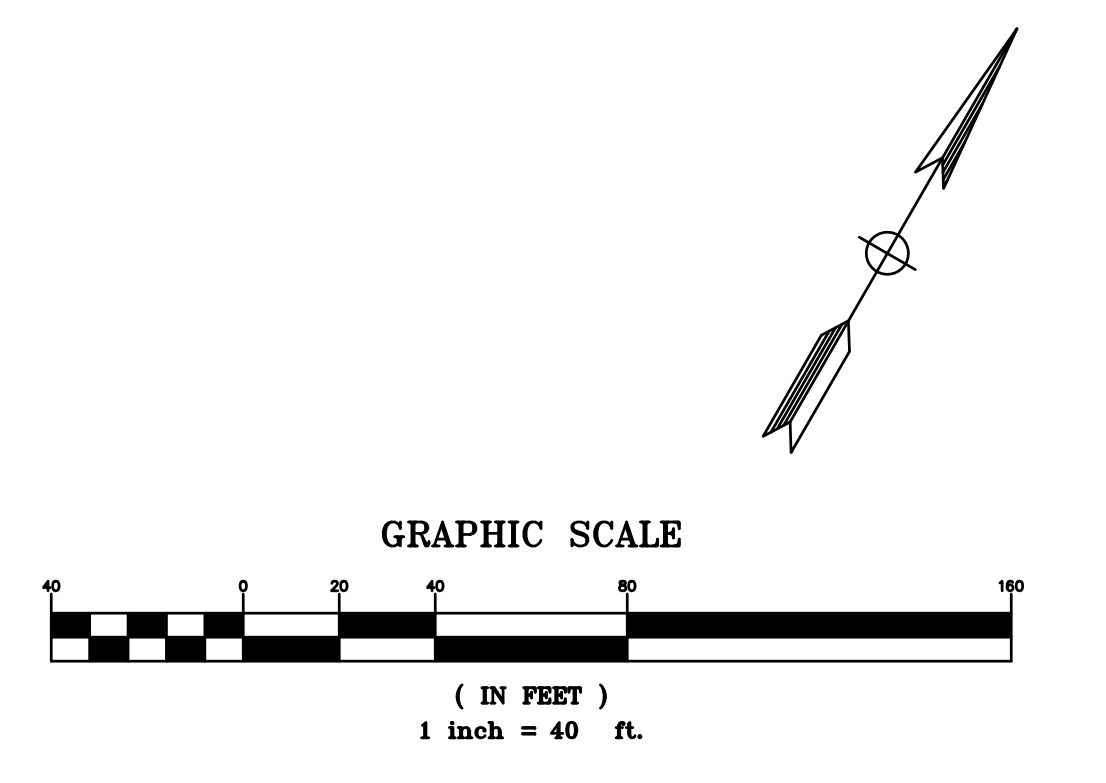

1. STATE DETAIL 9 (MOD. TYPE C MARKER)	8. STATE DETAIL 32	15. CHATTER BARS	22. BIKE LOOP DETECTOR SYMBOL
2. STATE DETAIL 12 (MOD. TYPE C MARKER)	9. STATE DETAIL 37B	16. RESERVED FOR FUTURE USE	23. RESERVED FOR FUTURE USE
3. STATE DETAIL 22	10. STATE DETAIL 38	17. SOLID 12" WHITE	24. YIELD LINE
4. RESERVED FOR FUTURE USE	11. STATE DETAIL 39	18. SOLID 12" YELLOW	25. GREEN PAVEMENT ENHANCEMENT
5. STATE DETAIL 25	12. STATE DETAIL 39A	19. SOLID 24" WHITE	26. RESERVED FOR FUTURE USE
6. STATE DETAIL 27B	13. RESERVED FOR FUTURE USE	20. STATE DETAIL 26 (MOD. 24" SPACING)	27. SOLID 24" YELLOW
7. STATE DETAIL 29	14. ARROW/MESSAGES	21. STATE DETAIL 40	28. STATE DETAIL 41

REVISIONS	DATE

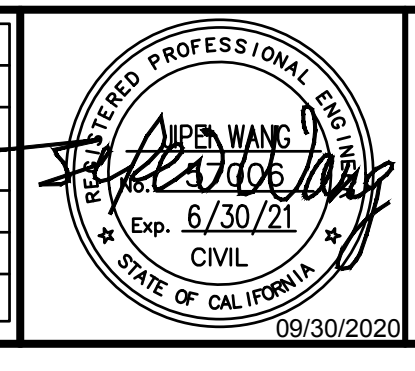

SAN ANTONIO STREET
BETWEEN S 17TH STREET AND S JACKSON AVENUE
SIGNING AND STRIPING PLAN

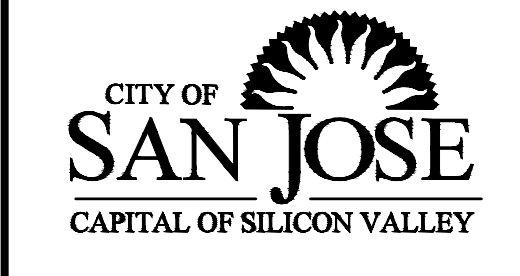

DEPARTMENT OF TRANSPORTATION SAN JOSE, CALIFORNIA	
DRAWN BY: _____	JOHN RISTOW DIRECTOR
CHECKED BY: _____	
PROJ MGR: _____	
DATE: _____	
SCALE: _____	
SHEET NO. 4 OF 11	FILE NO. _____

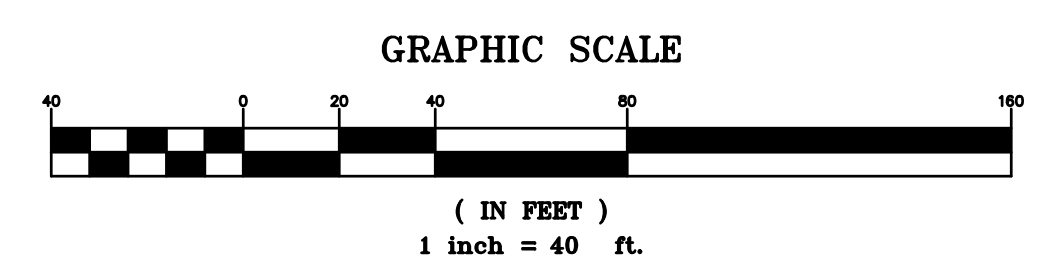
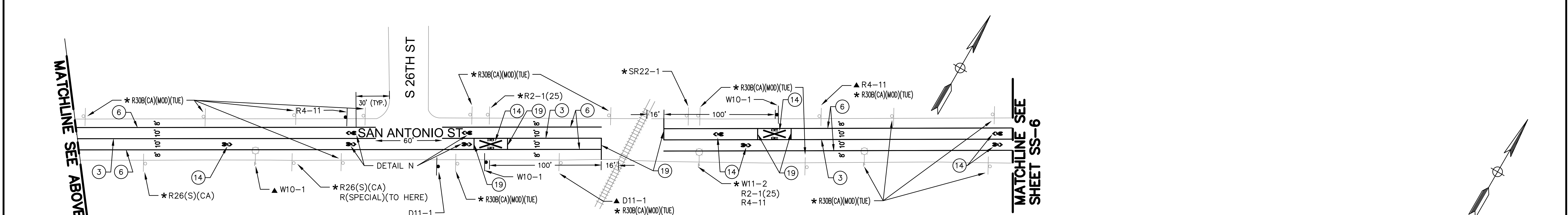
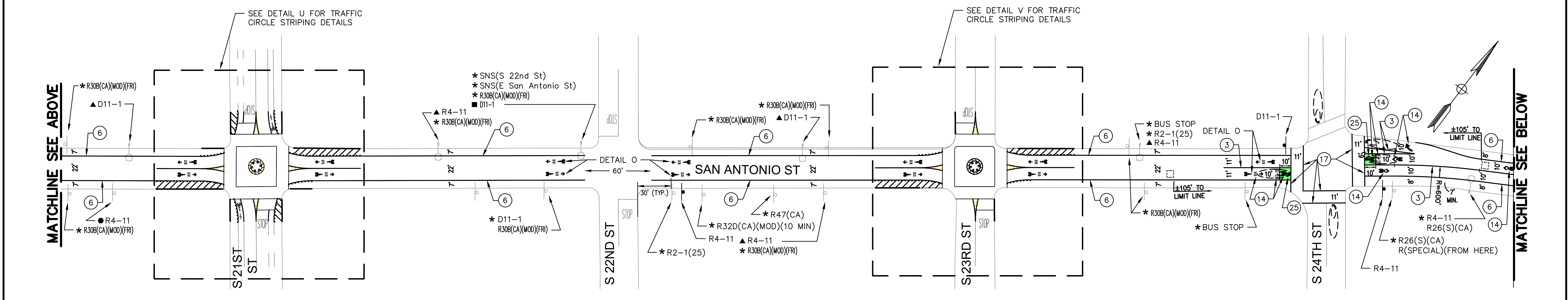
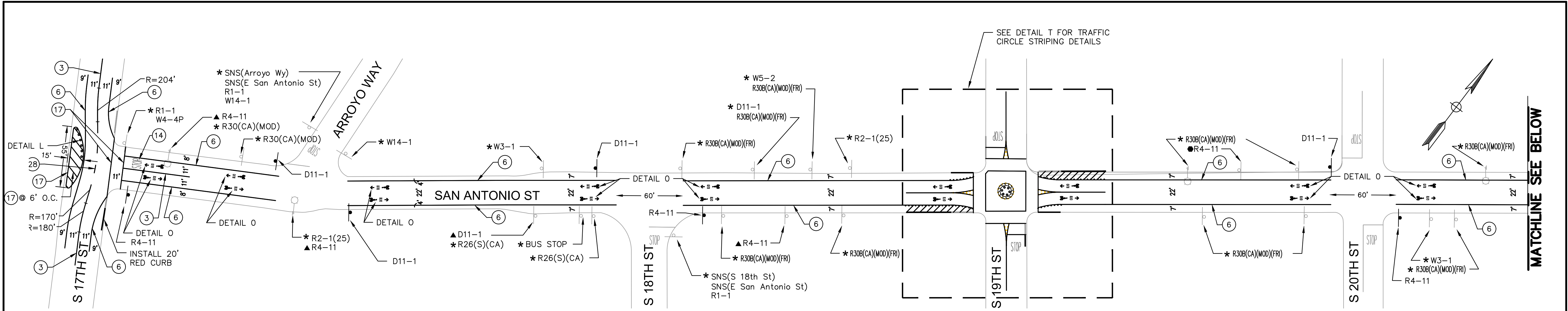

1. STATE DETAIL 9 (MOD, TYPE C MARKER)	8. STATE DETAIL 32	15. CHATTER BARS	22. BIKE LOOP DETECTOR SYMBOL
2. STATE DETAIL 12 (MOD, TYPE C MARKER)	9. STATE DETAIL 37B	16. RESERVED FOR FUTURE USE	23. RESERVED FOR FUTURE USE
3. STATE DETAIL 22	10. STATE DETAIL 38	17. SOLID 12" WHITE	24. YIELD LINE
4. RESERVED FOR FUTURE USE	11. STATE DETAIL 39	18. SOLID 12" YELLOW	25. GREEN PAVEMENT ENHANCEMENT
5. STATE DETAIL 25	12. STATE DETAIL 39A	19. SOLID 24" WHITE	26. RESERVED FOR FUTURE USE
6. STATE DETAIL 27B	13. RESERVED FOR FUTURE USE	20. STATE DETAIL 26 (MOD, 24" SPACING)	27. SOLID 24" YELLOW
7. STATE DETAIL 29	14. ARROW/MESSAGES	21. STATE DETAIL 40	28. STATE DETAIL 41

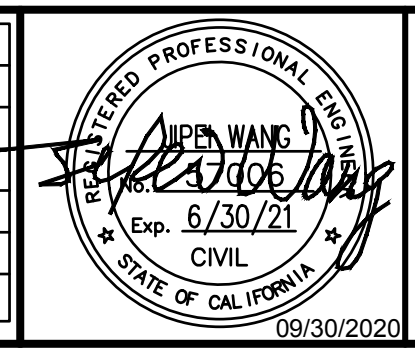

SAN ANTONIO STREET
BETWEEN S 17TH STREET AND S JACKSON AVENUE
SIGNING AND STRIPING PLAN



DEPARTMENT OF TRANSPORTATION SAN JOSE, CALIFORNIA	
DRAWN BY: _____	JOHN RISTOW DIRECTOR
CHECKED BY: _____	
PROJ MGR: _____	
DATE: _____	
SCALE: _____	
SHEET NO. <u>5</u> OF <u>11</u>	FILE NO. _____

MATCHLINE SEE SHEET SS-5

MATCHLINE SEE SHEET SS-7

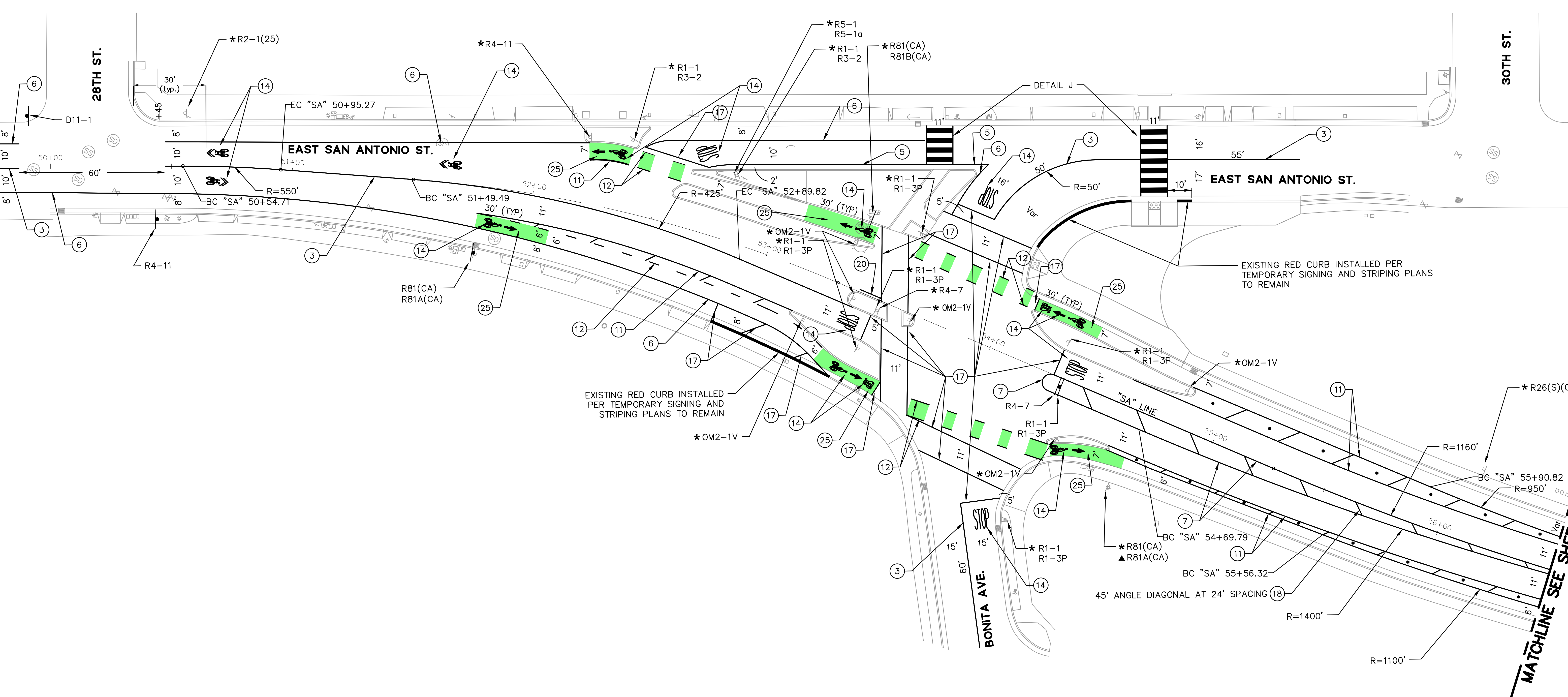

1. STATE DETAIL 9 (MOD. TYPE C MARKER)	8. STATE DETAIL 32	15. CHATTER BARS	22. BIKE LOOP DETECTOR SYMBOL
2. STATE DETAIL 12 (MOD. TYPE C MARKER)	9. STATE DETAIL 37B	16. RESERVED FOR FUTURE USE	23. RESERVED FOR FUTURE USE
3. STATE DETAIL 22	10. STATE DETAIL 38	17. SOLID 12" WHITE	24. YIELD LINE
4. RESERVED FOR FUTURE USE	11. STATE DETAIL 39	18. SOLID 12" YELLOW	25. GREEN PAVEMENT ENHANCEMENT
5. STATE DETAIL 25	12. STATE DETAIL 39A	19. SOLID 24" WHITE	26. RESERVED FOR FUTURE USE
6. STATE DETAIL 27B	13. RESERVED FOR FUTURE USE	20. STATE DETAIL 26 (MOD. 24' SPACING)	27. SOLID 24" YELLOW
7. STATE DETAIL 29	14. ARROW/MESSAGES	21. STATE DETAIL 40	28. STATE DETAIL 41

NO.	REVISIONS	DATE
6		
5		
4		
3		
2		
1		

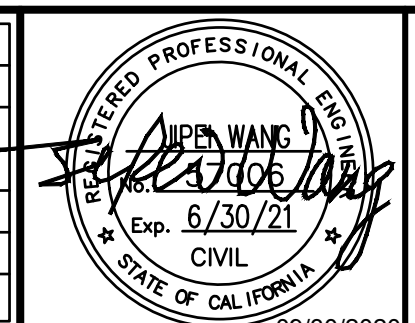

**SAN ANTONIO STREET
BETWEEN S 17TH STREET AND S JACKSON AVENUE
SIGNING AND STRIPING PLAN**



**DEPARTMENT OF TRANSPORTATION
SAN JOSE, CALIFORNIA**

DRAWN BY: _____	JOHN RISTOW DIRECTOR
CHECKED BY: _____	
PROJ MGR: _____	
DATE: _____	
SCALE: _____	
SHEET NO. <u>6</u> OF <u>11</u>	FILE NO. _____

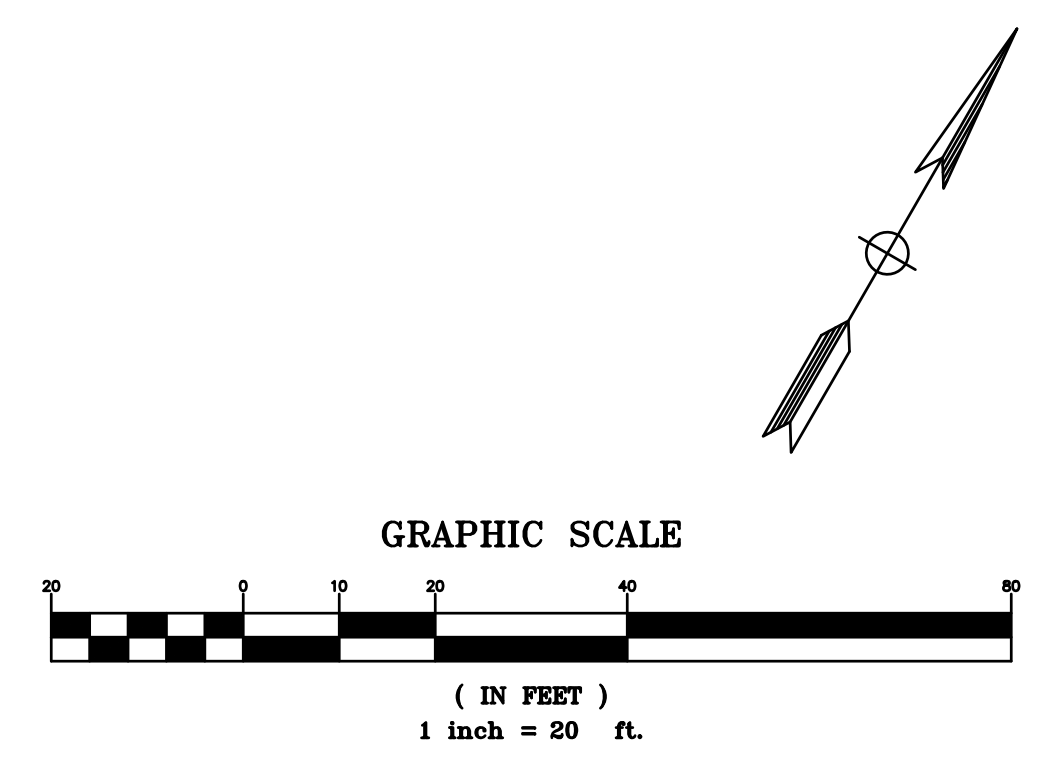
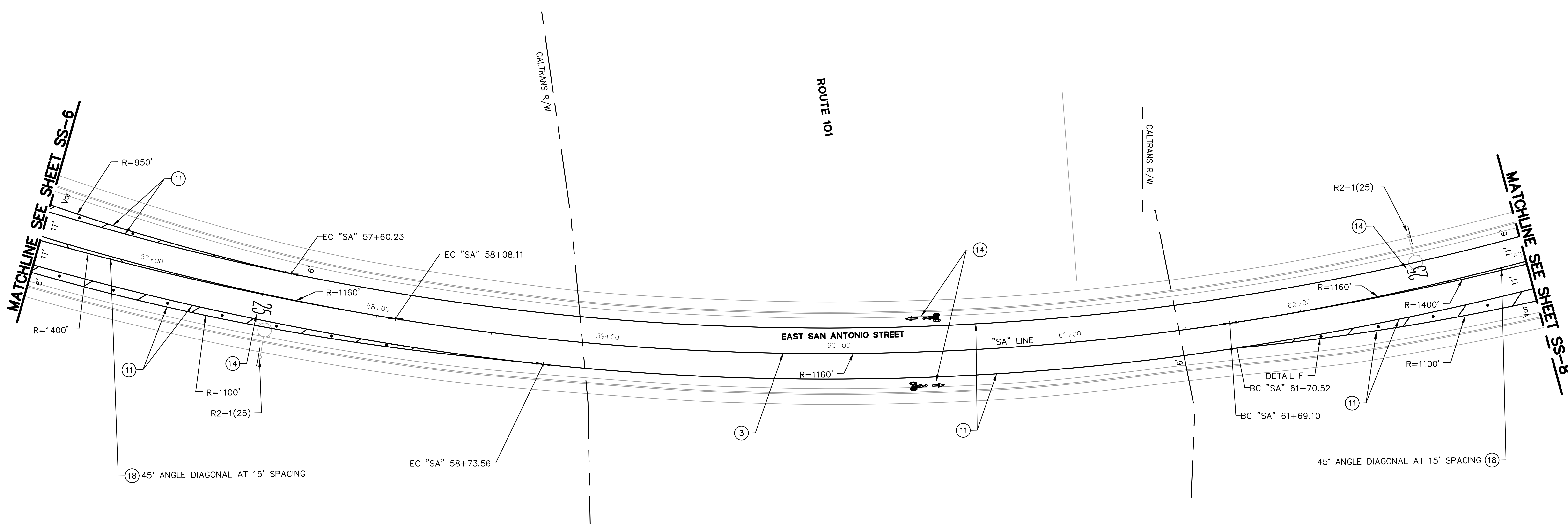

1. STATE DETAIL 9 (MOD. TYPE C MARKER)	8. STATE DETAIL 32	15. CHATTER BARS	22. BIKE LOOP DETECTOR SYMBOL
2. STATE DETAIL 12 (MOD. TYPE C MARKER)	9. STATE DETAIL 37B	16. RESERVED FOR FUTURE USE	23. RESERVED FOR FUTURE USE
3. STATE DETAIL 22	10. STATE DETAIL 38	17. SOLID 12" WHITE	24. YIELD LINE
4. RESERVED FOR FUTURE USE	11. STATE DETAIL 39	18. SOLID 12" YELLOW	25. GREEN PAVEMENT ENHANCEMENT
5. STATE DETAIL 25	12. STATE DETAIL 39A	19. SOLID 24" WHITE	26. RESERVED FOR FUTURE USE
6. STATE DETAIL 27B	13. RESERVED FOR FUTURE USE	20. STATE DETAIL 26 (MOD. 24" SPACING)	27. SOLID 24" YELLOW
7. STATE DETAIL 29	14. ARROW/MESSAGES	21. STATE DETAIL 40	28. STATE DETAIL 41

NO.	REVISIONS	DATE
6		
5		
4		
3		
2		
1		

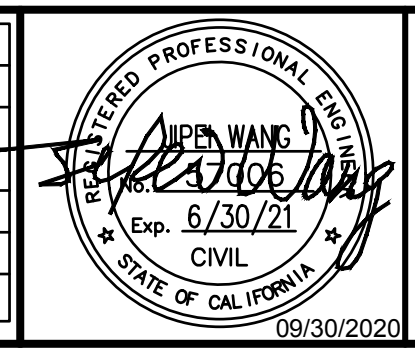

SAN ANTONIO STREET
 BETWEEN S 17TH STREET AND S JACKSON AVENUE
 SIGNING AND STRIPING PLAN



DEPARTMENT OF TRANSPORTATION SAN JOSE, CALIFORNIA	
DRAWN BY: _____ CHECKED BY: _____ PROJ MGR: _____ DATE: _____ SCALE: _____ SHEET NO. <u>7</u> OF <u>11</u>	JOHN RISTOW DIRECTOR _____ FILE NO. _____

MATCHLINE SEE SHEET SS-9

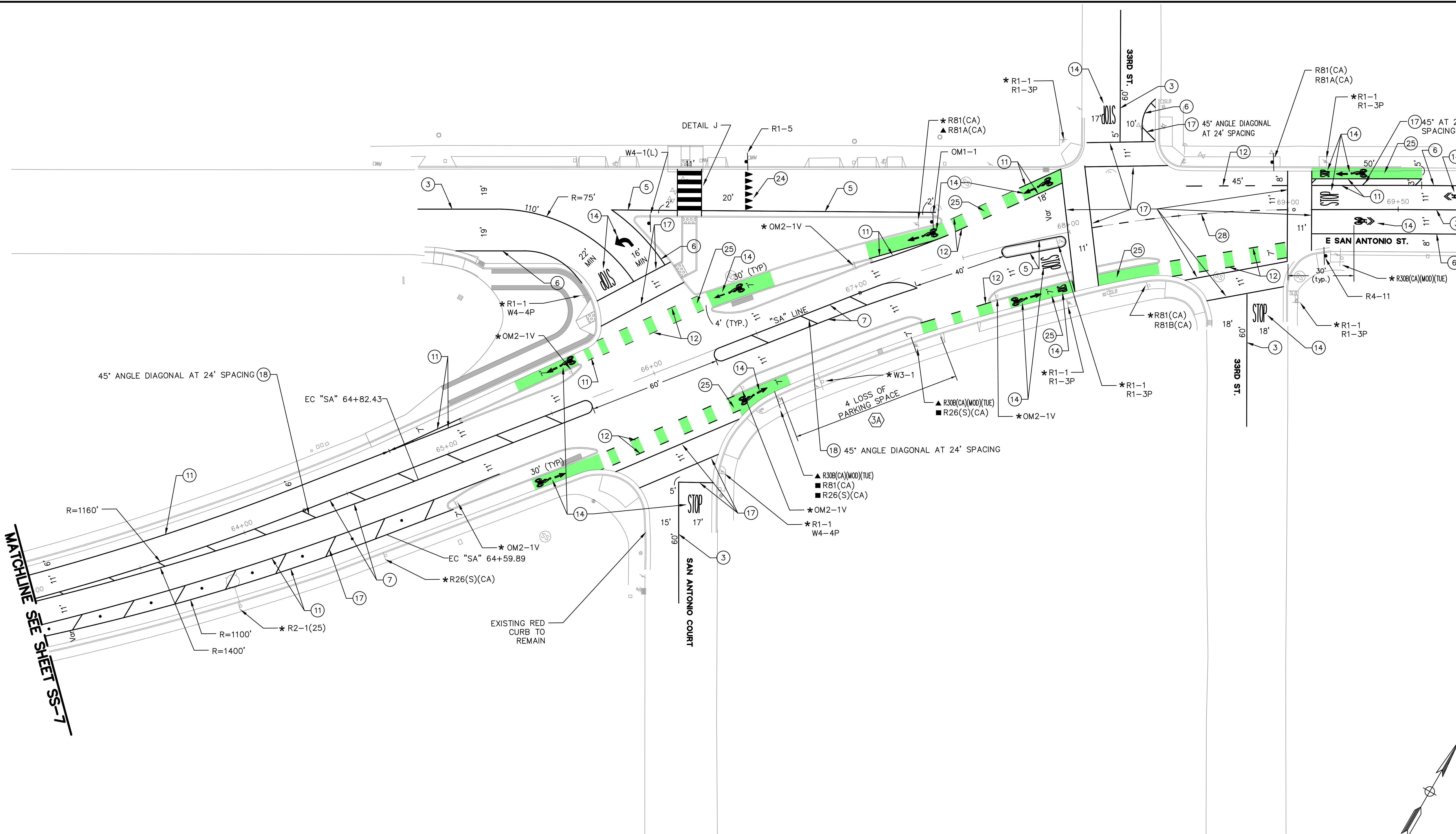

MATCHLINE SEE SHEET SS-7

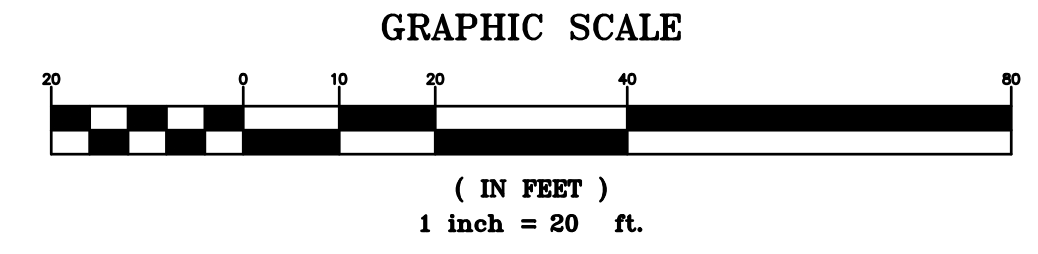

1. STATE DETAIL 9 (MOD. TYPE C MARKER)	8. STATE DETAIL 32	15. CHATTER BARS	22. BIKE LOOP DETECTOR SYMBOL
2. STATE DETAIL 12 (MOD. TYPE C MARKER)	9. STATE DETAIL 37B	16. RESERVED FOR FUTURE USE	23. RESERVED FOR FUTURE USE
3. STATE DETAIL 22	10. STATE DETAIL 38	17. SOLID 12" WHITE	24. YIELD LINE
4. RESERVED FOR FUTURE USE	11. STATE DETAIL 39	18. SOLID 12" YELLOW	25. GREEN PAVEMENT ENHANCEMENT
5. STATE DETAIL 25	12. STATE DETAIL 39A	19. SOLID 24" WHITE	26. RESERVED FOR FUTURE USE
6. STATE DETAIL 27B	13. RESERVED FOR FUTURE USE	20. STATE DETAIL 26 (MOD. 24" SPACING)	27. SOLID 24" YELLOW
7. STATE DETAIL 29	14. ARROW/MESSAGES	21. STATE DETAIL 40	28. STATE DETAIL 41

NO.	REVISIONS	DATE
6		
5		
4		
3		
2		
1		

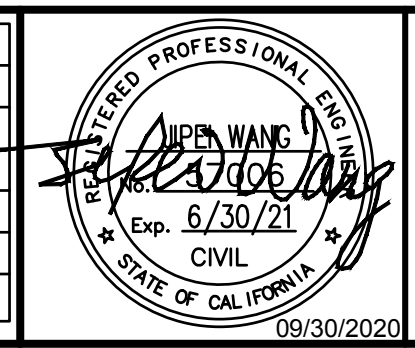

**SAN ANTONIO STREET
BETWEEN S 17TH STREET AND S JACKSON AVENUE
SIGNING AND STRIPING PLAN**



DEPARTMENT OF TRANSPORTATION SAN JOSE, CALIFORNIA	
DRAWN BY: _____	JOHN RISTOW DIRECTOR
CHECKED BY: _____	
PROJ MGR: _____	
DATE: _____	
SCALE: _____	
SHEET NO. <u>8</u> OF <u>11</u>	FILE NO. _____

MATCHLINE SEE SHEET SS-8

MATCHLINE SEE BELOW

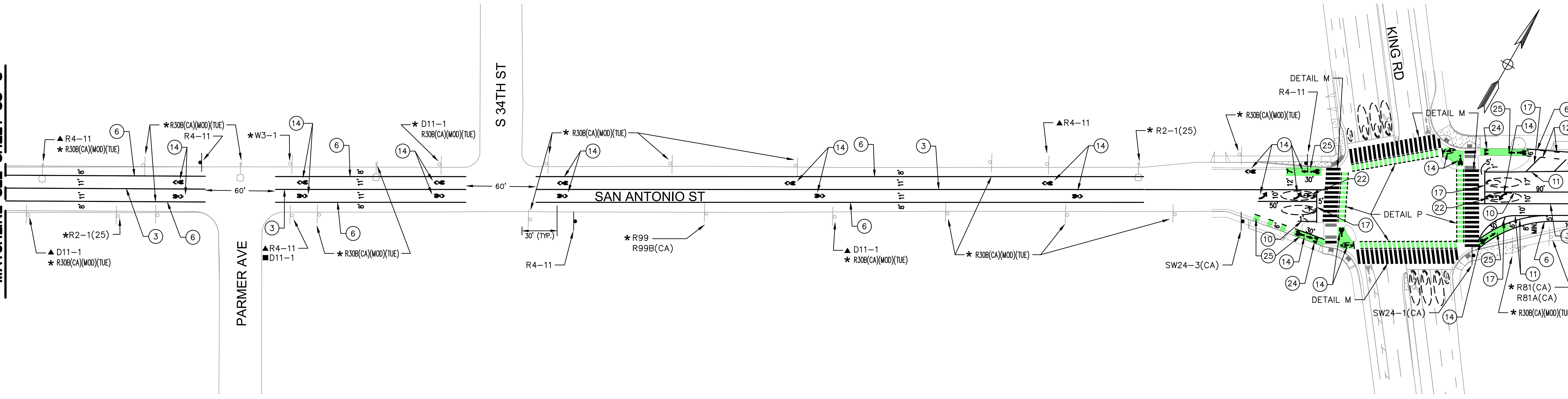

MATCHLINE SEE ABOVE

MATCHLINE SEE SHEET SS-10

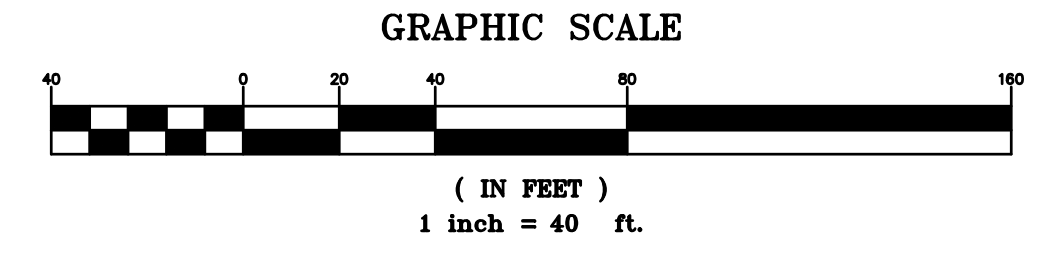
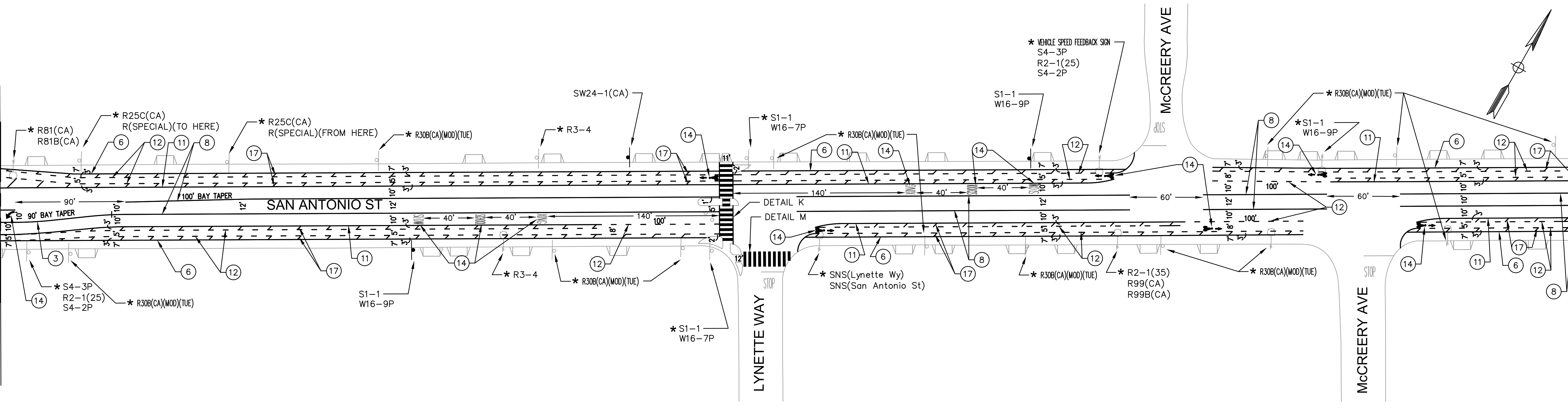

1. STATE DETAIL 9 (MOD, TYPE C MARKER)	8. STATE DETAIL 32	15. CHATTER BARS	22. BIKE LOOP DETECTOR SYMBOL	6	
2. STATE DETAIL 12 (MOD, TYPE C MARKER)	9. STATE DETAIL 37B	16. RESERVED FOR FUTURE USE	23. RESERVED FOR FUTURE USE	5	
3. STATE DETAIL 22	10. STATE DETAIL 38	17. SOLID 12" WHITE	24. YIELD LINE	4	
4. RESERVED FOR FUTURE USE	11. STATE DETAIL 39	18. SOLID 12" YELLOW	25. GREEN PAVEMENT ENHANCEMENT	3	
5. STATE DETAIL 25	12. STATE DETAIL 39A	19. SOLID 24" WHITE	26. RESERVED FOR FUTURE USE	2	
6. STATE DETAIL 27B	13. RESERVED FOR FUTURE USE	20. STATE DETAIL 26 (MOD, 24" SPACING)	27. SOLID 24" YELLOW	1	
7. STATE DETAIL 29	14. ARROW/MESSAGES	21. STATE DETAIL 40	28. STATE DETAIL 41		

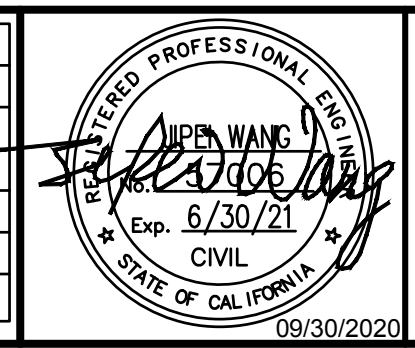

SAN ANTONIO STREET
BETWEEN S 17TH STREET AND S JACKSON AVENUE
SIGNING AND STRIPING PLAN



DEPARTMENT OF TRANSPORTATION
SAN JOSE, CALIFORNIA

DRAWN BY:	JOHN RISTOW
CHECKED BY:	DIRECTOR
PROJ MGR:	
DATE:	
SCALE:	
SHEET NO. 9	OF 11
FILE NO.:	

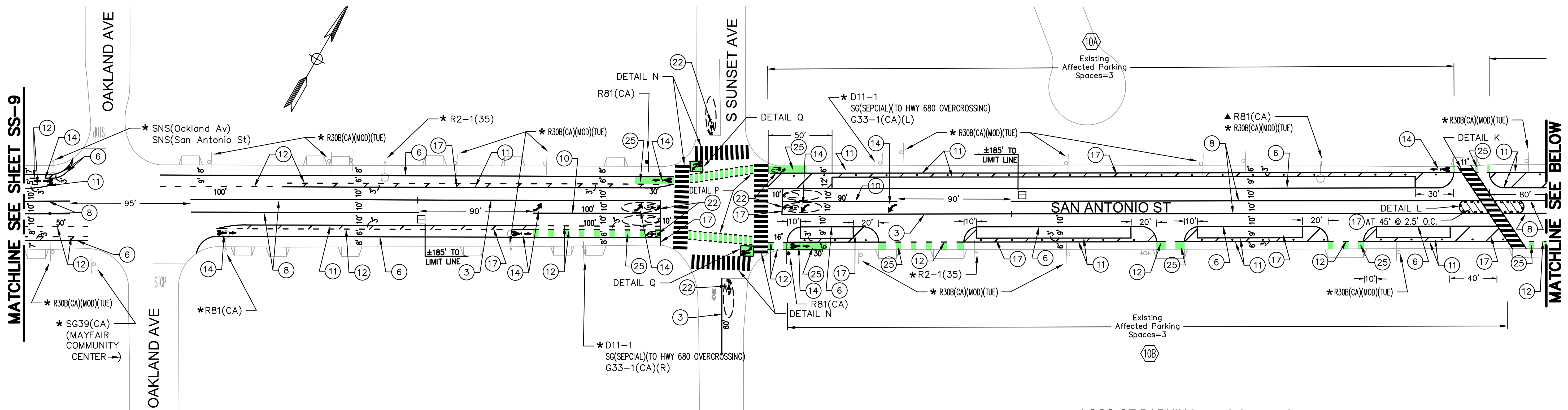

LOSS OF PARKING (THIS SHEET ONLY)

LOCATION	LOSS OF PARKING SPACES
10A	3
10B	3
10C	4
10D	5
10E	2
TOTAL	17

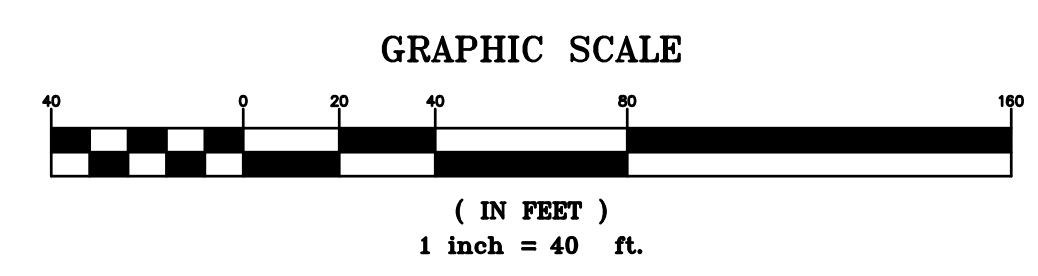
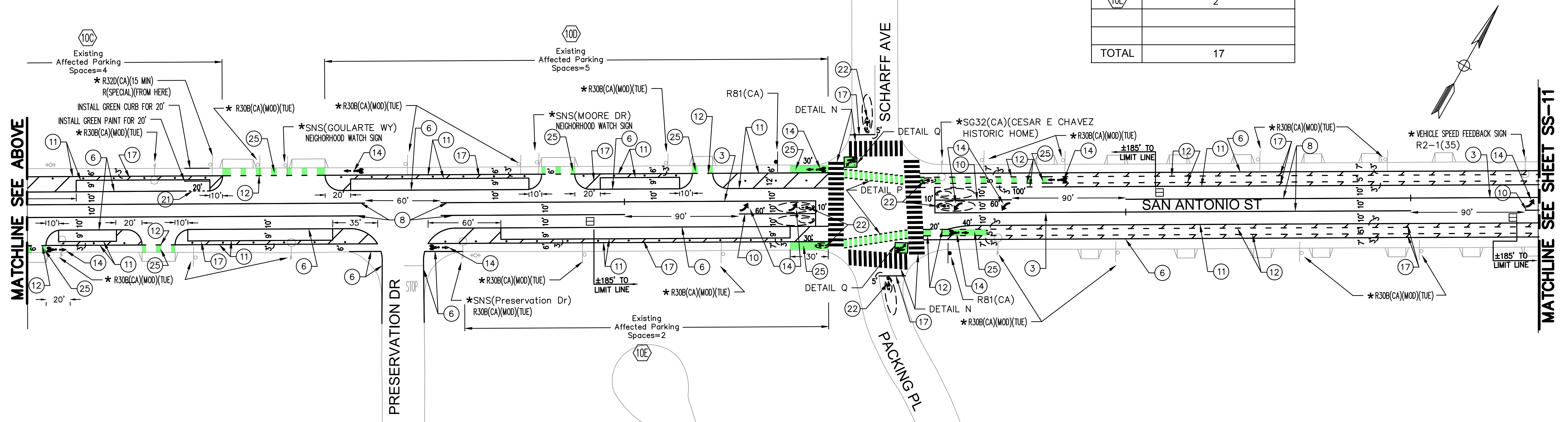

1. STATE DETAIL 9 (MOD, TYPE C MARKER)	8. STATE DETAIL 32	15. CHATTER BARS	22. BIKE LOOP DETECTOR SYMBOL
2. STATE DETAIL 12 (MOD, TYPE C MARKER)	9. STATE DETAIL 37B	16. RESERVED FOR FUTURE USE	23. RESERVED FOR FUTURE USE
3. STATE DETAIL 22	10. STATE DETAIL 38	17. SOLID 12" WHITE	24. YIELD LINE
4. RESERVED FOR FUTURE USE	11. STATE DETAIL 39	18. SOLID 12" YELLOW	25. GREEN PAVEMENT ENHANCEMENT
5. STATE DETAIL 25	12. STATE DETAIL 39A	19. SOLID 24" WHITE	26. RESERVED FOR FUTURE USE
6. STATE DETAIL 27B	13. RESERVED FOR FUTURE USE	20. STATE DETAIL 26 (MOD, 24" SPACING)	27. SOLID 24" YELLOW
7. STATE DETAIL 29	14. ARROW/MESSAGES	21. STATE DETAIL 40	28. STATE DETAIL 41

NO.	REVISIONS	DATE
6		
5		
4		
3		
2		
1		

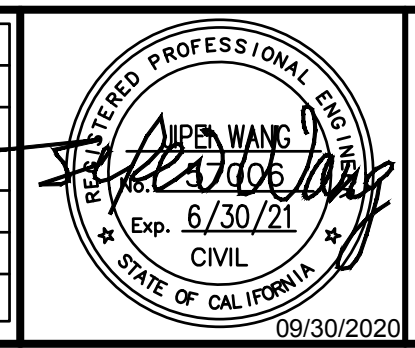

SAN ANTONIO STREET
BETWEEN S 17TH STREET AND S JACKSON AVENUE
SIGNING AND STRIPING PLAN



DEPARTMENT OF TRANSPORTATION SAN JOSE, CALIFORNIA	
DRAWN BY:	JOHN RISTOW DIRECTOR
CHECKED BY:	
PROJ MGR:	
DATE:	
SCALE:	
SHEET NO. 10	OF 11
FILE NO.:	

MATCHLINE SEE SHEET SS-10

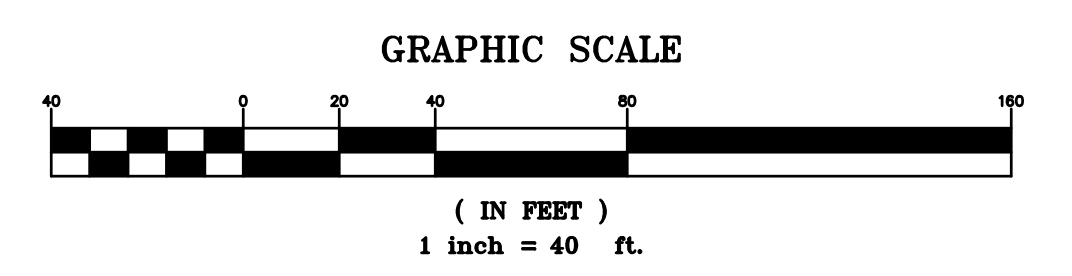
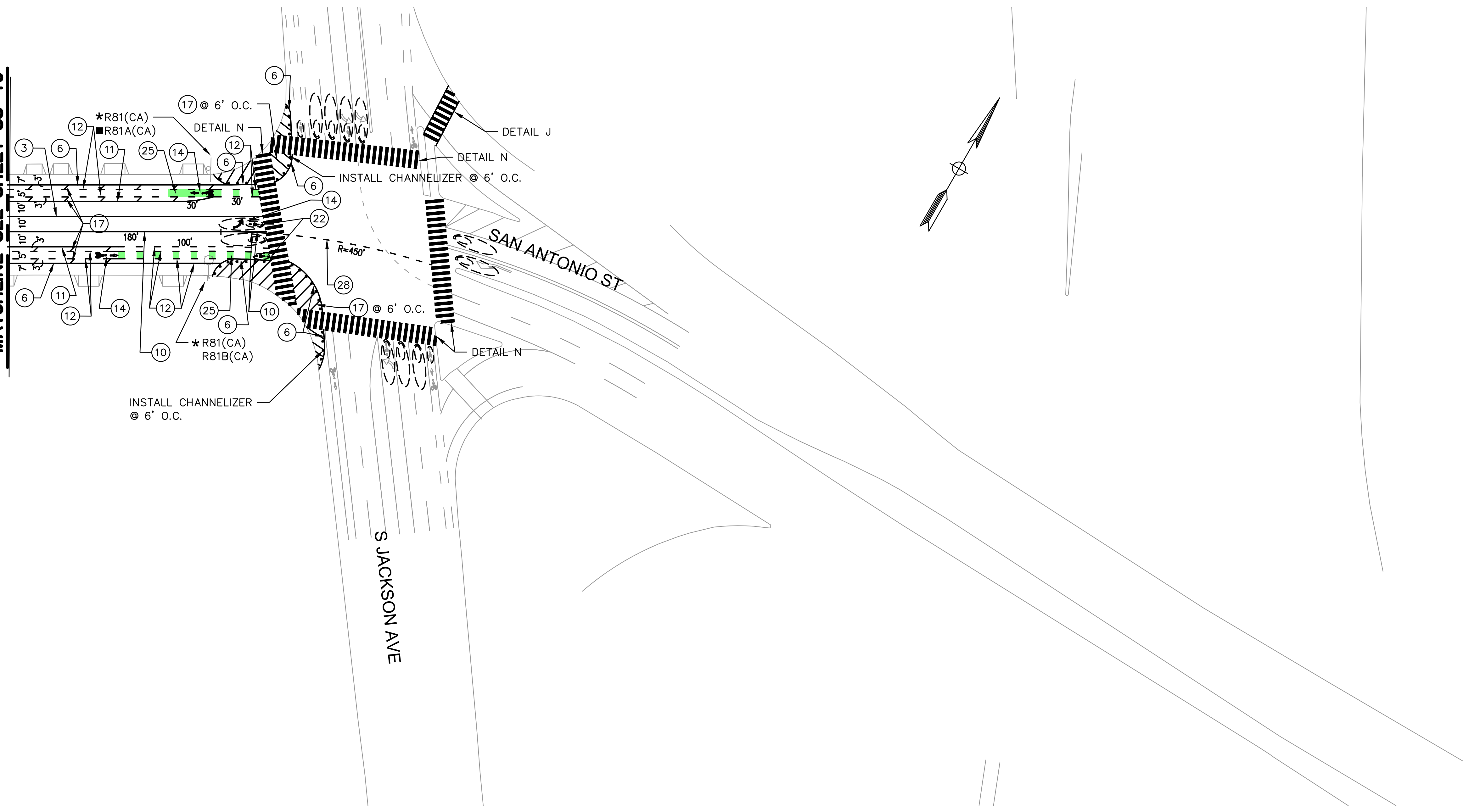

1. STATE DETAIL 9 (MOD. TYPE C MARKER)	8. STATE DETAIL 32	15. CHATTER BARS	22. BIKE LOOP DETECTOR SYMBOL
2. STATE DETAIL 12 (MOD. TYPE C MARKER)	9. STATE DETAIL 37B	16. RESERVED FOR FUTURE USE	23. RESERVED FOR FUTURE USE
3. STATE DETAIL 22	10. STATE DETAIL 38	17. SOLID 12" WHITE	24. YIELD LINE
4. RESERVED FOR FUTURE USE	11. STATE DETAIL 39	18. SOLID 12" YELLOW	25. GREEN PAVEMENT ENHANCEMENT
5. STATE DETAIL 25	12. STATE DETAIL 39A	19. SOLID 24" WHITE	26. RESERVED FOR FUTURE USE
6. STATE DETAIL 27B	13. RESERVED FOR FUTURE USE	20. STATE DETAIL 26 (MOD. 24" SPACING)	27. SOLID 24" YELLOW
7. STATE DETAIL 29	14. ARROW/MESSAGES	21. STATE DETAIL 40	28. STATE DETAIL 41

NO.	REVISIONS	DATE
6		
5		
4		
3		
2		
1		

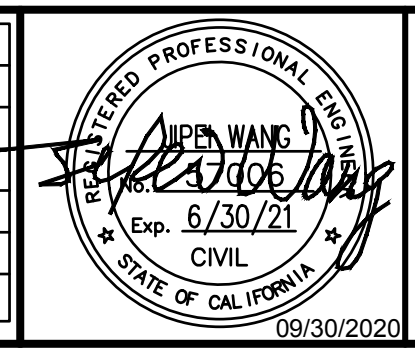

SAN ANTONIO STREET
BETWEEN S 17TH STREET AND S JACKSON AVENUE
SIGNING AND STRIPING PLAN

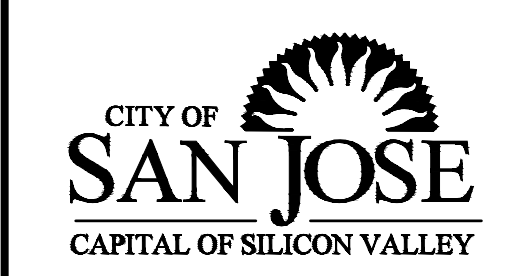

DEPARTMENT OF TRANSPORTATION SAN JOSE, CALIFORNIA	
DRAWN BY: _____	JOHN RISTOW DIRECTOR
CHECKED BY: _____	
PROJ MGR: _____	
DATE: _____	
SCALE: _____	
SHEET NO. 11 OF 11	FILE NO. _____