

## CALIFORNIA FIRE CODE – MATRIX ADOPTION TABLE APPENDIX D – FIRE APPARATUS ACCESS ROADS

(Matrix Adoption Tables are nonregulatory, intended only as an aid to the code user.  
See Chapter 1 for state agency authority and building applications.)

**(Not adopted by the State Fire Marshal)**

Adopting Agency	BSC	BSC- CG	SFM		HCD			DSA		OSHPD					BSCC	DPH	AGR	DWR	CEC	CA	SL	SLC
			T-24	T-19*	1	2	1/AC	AC	SS	1	1R	2	3	4								
Adopt Entire Chapter																						
Adopt Entire Chapter as amended (amended sections listed below)																						
Adopt only those sections that are listed below																						
[California Code of Regulations, Title 19, Division 1]																						
Chapter / Section																						

\* The *California Code of Regulations* (CCR), Title 19, Division 1 provisions that are found in the *California Fire Code* are a reprint from the current CCR, Title 19, Division 1 text for the code user's convenience only. The scope, applicability and appeals procedures of CCR, Title 19, Division I remain the same.

## APPENDIX D

# FIRE APPARATUS ACCESS ROADS

*The provisions contained in this appendix are not mandatory unless specifically referenced in the adopting ordinance or legislation of the jurisdiction.*

---

### User note:

**About this appendix:** Appendix D contains more detailed elements for use with the basic access requirements found in Section 503, which gives some minimum criteria, such as a maximum length of 150 feet and a minimum width of 20 feet, but in many cases does not state specific criteria. This appendix, like Appendices B and C, is a tool for jurisdictions looking for guidance in establishing access requirements and includes criteria for multiple-family residential developments, large one- and two-family subdivisions, specific examples for various types of turnarounds for fire department apparatus and parking regulatory signage.

---

### SECTION D101 GENERAL

**D101.1 Scope.** Fire apparatus access roads shall be in accordance with this appendix and all other applicable requirements of the *California Fire Code*.

### SECTION D102 REQUIRED ACCESS

**D102.1 Access and loading.** Facilities, buildings or portions of buildings hereafter constructed shall be accessible to fire department apparatus by way of an approved fire apparatus access road with an asphalt, concrete or other approved driv-

ing surface capable of supporting the imposed load of fire apparatus weighing up to 75,000 pounds (34 050 kg).

### SECTION D103 MINIMUM SPECIFICATIONS

**D103.1 Access road width with a hydrant.** Where a fire hydrant is located on a fire apparatus access road, the minimum road width shall be 26 feet (7925 mm), exclusive of shoulders (see Figure D103.1).

**D103.2 Grade.** Fire apparatus access roads shall not exceed 10 percent in grade.

**Exception:** Grades steeper than 10 percent as approved by the fire code official.

**See insert page for San Jose Fire Department amended Figure D103.1 Dead  
- End Apparatus Access Road Turnaround**

(SJFD Adoption)

2019 CALIFORNIA FIRE CODE

**INTERNATIONAL CODE COUNCIL®**

Copyright © 2019 ICC. ALL RIGHTS RESERVED. Accessed by Loretta Perez (loretta.perez@sanjoseca.gov), (San Jose Fire Department) Order Number #100729097 on Jul 12, 2019 03:15 PM (PDT) pursuant to License Agreement with ICC. No further reproduction or distribution authorized. Single user only, copying and networking prohibited. ANY UNAUTHORIZED REPRODUCTION OR DISTRIBUTION IS A VIOLATION OF THE FEDERAL COPYRIGHT ACT AND THE LICENSE AGREEMENT, AND SUBJECT TO CIVIL AND CRIMINAL PENALTIES THEREUNDER.

763

# San Jose Fire Department Amended Figure D103.1 Dead-End Fire Apparatus Access Road Turnaround

Not to Scale

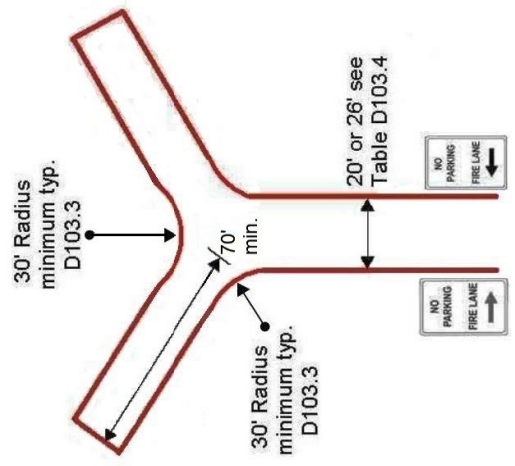
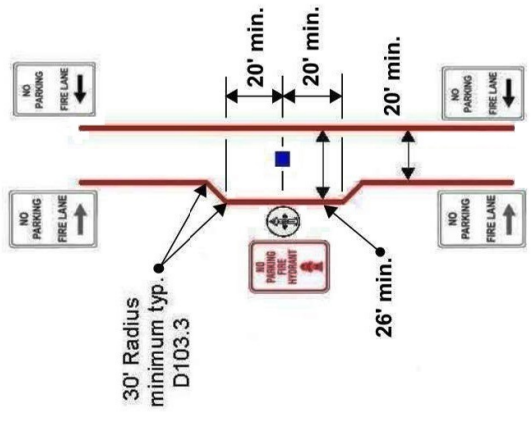

"Y"

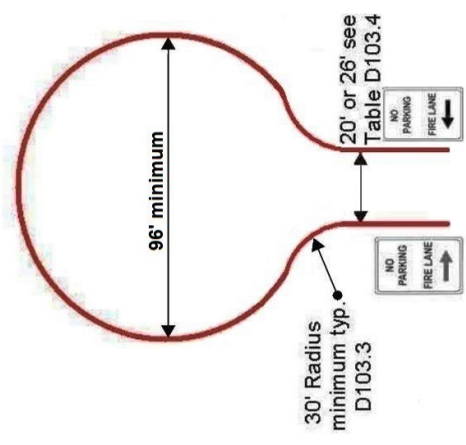

Cul-De-Sac

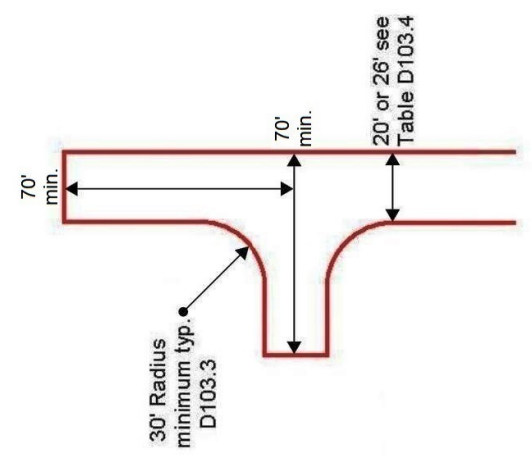

Alternative Hammerhead

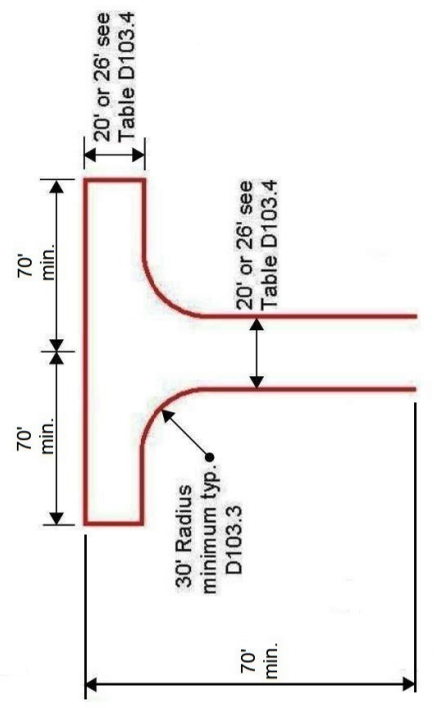

Hammerhead

## Access Road Width Examples

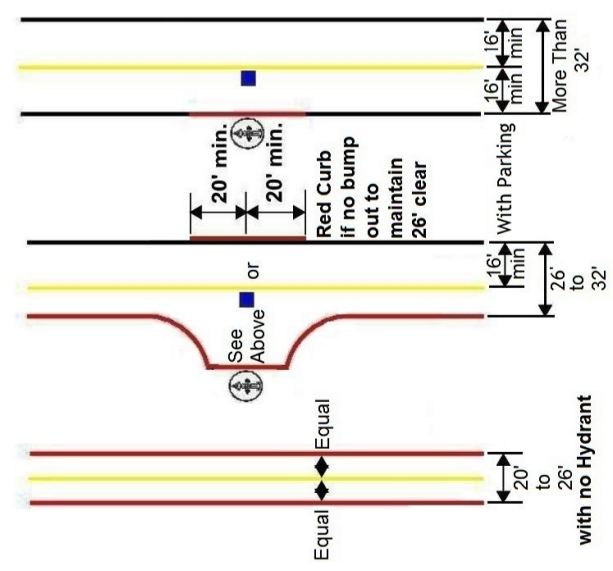

## APPENDIX D

**D103.3 Turning radius.** The minimum turning radius shall be **30 feet inside, 50 feet outside.**

**D103.4 Dead ends.** Dead-end fire apparatus access roads in excess of 150 feet (45 720 mm) shall be provided with width and turnaround provisions in accordance with Table D103.4. **As amended**

**TABLE D103.4  
REQUIREMENTS FOR DEAD-END  
FIRE APPARATUS ACCESS ROADS**

LENGTH (feet)	WIDTH (feet)	TURNAROUNDS REQUIRED
0–150	20	None required
151–500	20	Hammerhead, “Y” or cul-de-sac in accordance with Figure D103.1 <b>As amended</b>
501–750	26	Hammerhead, “Y” or cul-de-sac in accordance with Figure D103.1 <b>As amended</b>
Over 750		Special approval required

For SI: 1 foot = 304.8 mm.

**D103.5 Fire apparatus access road gates.** Gates securing the fire apparatus access roads shall comply with all of the following criteria:

1. Where a single gate is provided, the gate width shall be not less than 20 feet (6096 mm). Where a fire apparatus road consists of a divided roadway, the gate width shall be not less than **14 feet.**
2. Gates shall be of the swinging or sliding type.
3. Construction of gates shall be of materials that allow manual operation by one person.
4. Gate components shall be maintained in an operative condition at all times and replaced or repaired when defective.
5. Electric gates shall be equipped with a means of opening the gate by fire department personnel for emergency access. Emergency opening devices shall be approved by the fire code official.
6. Methods of locking shall be submitted for approval by the fire code official.
7. Electric gate operators, where provided, shall be listed in accordance with UL 325.
8. Gates intended for automatic operation shall be designed, constructed and installed to comply with the requirements of ASTM F2200.

**D103.6 Signs.** Where required by the fire code official, fire apparatus access roads shall be marked with permanent NO PARKING—FIRE LANE signs complying with Figure D103.6. Signs shall have a minimum dimension of 12 inches (305 mm) wide by 18 inches (457 mm) high and have red letters on a white reflective background. Signs shall be posted

on one or both sides of the fire apparatus road as required by Section D103.6.1 or D103.6.2.

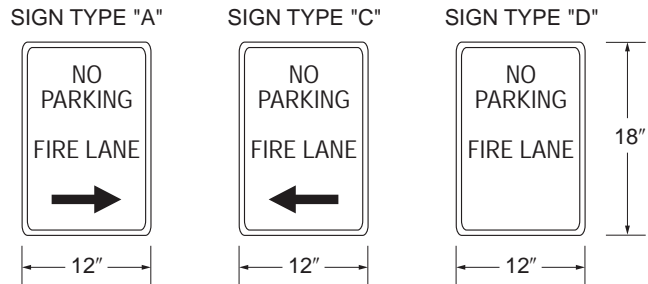

**FIGURE D103.6  
FIRE LANE SIGNS**

**D103.6.1 Roads 20 to 26 feet in width.** Fire lane signs as specified in Section D103.6 shall be posted on both sides of fire apparatus access roads that are 20 to 26 feet wide (6096 to 7925 mm).

**D103.6.2 Roads more than 26 feet in width.** Fire lane signs as specified in Section D103.6 shall be posted on one side of fire apparatus access roads more than 26 feet wide (7925 mm) and less than 32 feet wide (9754 mm).

## SECTION D104 COMMERCIAL AND INDUSTRIAL DEVELOPMENTS

**D104.1 Buildings exceeding three stories or 30 feet in height.** Buildings or facilities exceeding 30 feet (9144 mm) or three stories in height shall have not fewer than two means of fire apparatus access for each structure.

**D104.2 Buildings exceeding 62,000 square feet in area.** Buildings or facilities having a gross building area of more than 62,000 square feet (5760 m<sup>2</sup>) shall be provided with two separate and approved fire apparatus access roads.

**Exception:** Projects having a gross building area of up to 124,000 square feet (11 520 m<sup>2</sup>) that have a single approved fire apparatus access road where all buildings are equipped throughout with approved automatic sprinkler systems.

**D104.3 Remoteness.** Where two fire apparatus access roads are required, they shall be placed a distance apart equal to not less than one half of the length of the maximum overall diagonal dimension of the lot or area to be served, measured in a straight line between accesses.

## SECTION D105 AERIAL FIRE APPARATUS ACCESS ROADS

**D105.1 Where required.** Where the vertical distance between the grade plane and the highest roof surface exceeds 30 feet (9144 mm), approved aerial fire apparatus access

roads shall be provided. For purposes of this section, the highest roof surface shall be determined by measurement to the eave of a pitched roof, the intersection of the roof to the exterior wall, or the top of parapet walls, whichever is greater.

**D105.2 Width.** Aerial fire apparatus access roads shall have a minimum unobstructed width of 26 feet (7925 mm), exclusive of shoulders, in the immediate vicinity of the building or portion thereof.

**D105.3 Proximity to building.** One or more of the required access routes meeting this condition shall be located not less than 15 feet (4572 mm) and not greater than 30 feet (9144 mm) from the building, and shall be positioned parallel to one entire side of the building. The side of the building on which the aerial fire apparatus access road is positioned shall be approved by the fire code official.

**D105.4 Obstructions.** Overhead utility and power lines shall not be located over the aerial fire apparatus access road or between the aerial fire apparatus road and the building. Other obstructions shall be permitted to be placed with the approval of the fire code official.

### SECTION D106

#### MULTIPLE-FAMILY RESIDENTIAL DEVELOPMENTS

**D106.1 Projects having more than 100 dwelling units.** Multiple-family residential projects having more than 100 dwelling units shall be equipped throughout with two separate and approved fire apparatus access roads.

**Exception:** Projects having up to 200 dwelling units shall have not fewer than one approved fire apparatus access road where all buildings, including nonresidential occupancies, are equipped throughout with approved automatic sprinkler systems installed in accordance with Section 903.3.1.1 or 903.3.1.2.

**D106.2 Projects having more than 200 dwelling units.** Multiple-family residential projects having more than 200 dwelling units shall be provided with two separate and approved fire apparatus access roads regardless of whether they are equipped with an approved automatic sprinkler system.

**D106.3 Remoteness.** Where two fire apparatus access roads are required, they shall be placed a distance apart equal to not less than one-half of the length of the maximum overall diagonal dimension of the property or area to be served, measured in a straight line between accesses.

### SECTION D107

#### ONE- OR TWO-FAMILY RESIDENTIAL DEVELOPMENTS

**D107.1 One- or two-family dwelling residential developments.** Developments of one- or two-family dwellings where the number of dwelling units exceeds 30 shall be provided with two separate and approved fire apparatus access roads.

##### Exceptions:

1. Where there are more than 30 dwelling units on a single public or private fire apparatus access road

and all dwelling units are equipped throughout with an approved automatic sprinkler system in accordance with Section 903.3.1.1, 903.3.1.2 or 903.3.1.3, access from two directions shall not be required.

2. The number of dwelling units on a single fire apparatus access road shall not be increased unless fire apparatus access roads will connect with future development, as determined by the fire code official.

**D107.2 Remoteness.** Where two fire apparatus access roads are required, they shall be placed a distance apart equal to not less than one-half of the length of the maximum overall diagonal dimension of the property or area to be served, measured in a straight line between accesses.

### SECTION D108 REFERENCED STANDARDS

ASTM	F2200—14	Standard Specification for Automated Vehicular Gate Construction	D103.5
UL	325—02	Door, Drapery, Gate, Louver, and Window Operators and Systems, with Revisions through May 2015	D103.5